

49810SKDOWA225COW11 0993 9999
KUOW RADIO
D S 50 UNIV OF WASH
325 COMMUNICATIONS BLDG
SEATTLE WA 98195

INTRODUCING THE SMART MIC* SYSTEM



Actual Size

The most troublesome audio conditions can only be solved by today's most trouble free microphone system. The Shure Automatic Microphone System.

Total integration is the key.

For the first time ever, Shure has combined microphone, mixer and logic technology in a dedicated, totally integrated system—so advanced, its conception marks the beginning of a sound revolution in conference rooms, teleconferencing, churches, legislative chambers, courtrooms—anywhere speech related multi-microphone systems are employed.

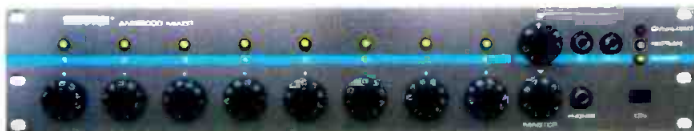

At the heart of Shure's Automatic Microphone System (AMS) are revolutionary, angle-sensitive microphones that turn on automatically *only* when addressed within their own 120° "window of acceptance." In addition, each microphone continuously samples its own local acoustic environment, and compensates for changing room audio conditions—automatically.

The Shure AMS incorporates advanced signal processing circuitry—turning on to the sound source quickly, quietly, and automatically—and turning off with a smooth whisper. From

beginning to end—no clicks, pops, noise "pumping," or missed syllables.

Logic terminals on the rear panel of every AMS mixer offer unprecedented flexibility for advancing the system's capabilities. For example, when connected with Shure's Video Switcher Interface, the AMS will control commercially available video switchers. And for large gatherings, AMS mixers (both 4 and 8 channel models available) can easily be combined to effectively control over 200 individual microphones.

Since the AMS operates as an integrated system, many adjustments and controls have been eliminated. As a result, no other unit sets up as quickly. And operation is so easy and automatic, the only adjustments necessary are individual volume controls.

For more information on the revolutionary new Automatic Microphone System, call or write Shure Brothers Inc., 222 Hartrey Ave., Evanston, IL 60204, (312) 866-2553.

*Microphones and Intelligent Circuitry

SHURE®

THE SOUND OF THE PROFESSIONALS®... WORLDWIDE

Circle 10 on Reader Service Card

www.americanradiohistory.com



PATENTS
PENDING

SBI-1086A



SEPTEMBER 1983 VOLUME 17 NO. 8

Publisher
Larry Zide

Associate Publisher
Elaine Zide

Editor
John M. Woram

Managing Editor
Mark B. Waldstein

Associate Editor
Ricki Zide

Technical Editor
Linda Cortese

European Editor
John Borwick

Layout & Design
Kathi Lippe

Advertising Coordinator
Karen Cohn

Book Sales
Lydia Calogrides

Circulation Manager
Eloise Beach

Graphics
K & S Graphics

Typography
Spartan Phototype Co.

FEATURES

RECORDING STUDIO CONSOLES AND FILM PRODUCTION 42	Gregory Hanks
db TEST REPORT: THE BRUEL & KJAER STUDIO MICROPHONES 46	John Monforte
LONG PLAYERS—LONG GONE 48	John T. Mullin
HOUSE SOUND REINFORCEMENT AT THE US FESTIVAL 52	Bob Anthony
COMPACT DISC ANALYSIS 56	Michael Tapes
SPARS—DATA TRACK 59	

DEPARTMENTS

LETTERS 4	CALENDAR 8	EDITORIAL 40	CLASSIFIED 71
THEORY AND PRACTICE 10			Ken Pohlmann
SOUND WITH IMAGES 19			Len Feldman
DIGITAL AUDIO 28			Barry Blesser
SOUND REINFORCEMENT 37			John Eargle
NEW PRODUCTS AND SERVICES 67			
PEOPLE, PLACES, HAPPENINGS 73			

db, the Sound Engineering Magazine (ISSN 0011-7145) is published monthly by Sagamore Publishing Company, Inc. Entire contents copyright © 1983 by Sagamore Publishing Co., 1120 Old Country Road, Plainview, L.I., N.Y. 11803. Telephone (516) 433-6530. db is published for those individuals and firms in professional audio-recording, broadcast, audio-visual, sound reinforcement, consultants, video recording, film sound, etc. Application should be made on the subscription form in the rear of each issue. Subscriptions are \$15.00 per year (\$28.00 per year outside U.S. Possessions, \$16.00 per year Canada) in U.S. funds. Single copies are \$1.95 each. Editorial, Publishing and Sales Offices: 1120 Old Country Road, Plainview, New York 11803. Controlled circulation postage paid at Plainview, NY 11803 and an additional mailing office.

MAGIC OR TRAGIC?

TO THE EDITOR:

Your June editorial about the possible advent of the "Tragic of Digital" should be carefully studied by those making digital recordings. If the public is going to pay the extra cost for CDs, they will demand recordings of superior quality. I hope the recording industry will be able to make the transition to digital technology. However, it will require that a number of people start carefully listening to the records that they are making.

STEPHEN M. HEIDER
Buffalo, New York

WOW, WE NEED HELP

TO THE EDITOR:

First, my thanks for a very informative magazine. It helps expatriates like myself keep in touch with what's happening in pro' audio.

We need some help here at TWR (Trans-World Radio) in Swaziland. We have an identifying signal, and we would like to eliminate tape noise and wow-and-flutter when we transmit it. The signal is used at station sign-on, when three 15-second phrases are played by handbells, followed by a 5-second voice ID. This sequence is repeated for about five minutes. At sign-off, we transmit a single 15-second handbell phrase.

If it is possible, we'd like to have these two signal formats digitized, and loaded into EPROMs. This should give us computer call-up as needed, as well as good reproduction. We already have the automation needed to provide the commands.

We would like to hear from anyone able to EPROM our "pingles," and please—by AIR MAIL. Surface mail takes about three months.

CAL DONNER,
Studio Manager
Trans-World Radio
P.O. Box 64
Manzini, Swaziland

db replies:

How about it readers? Can anyone help TWR?

MAKING A POINT (FOUR, ACTUALLY)

TO THE EDITOR:

Please permit me to make four comments regarding Mr. Levinson's letter in June's db.

First, I did not provide Mr. Levinson with copies of our two patents or any test data. Mr. Codomo may have done so, which of course is quite alright.

Second, I did not conduct the experiments; they were conducted by certified clinical audiologists, a very competent otologist, and a very knowledgeable neurologist. There was no possibility of any patient deriving answers to the word discrimination tests (the ultimate test of any hearing aid) by means of lip reading, sign language, or cue cards; all the patient's information had to come to him through the Cortical Hearing Aid. In no case did I work directly with a patient; only the audiologist and the otologist did that. (I only designed and built the equipment.)

Third, the conclusions presented in my article were the unanimous conclusions of the audiologists, the otologist, and the neurologist referenced in the acknowledgments. I am profoundly grateful to all of them for their active involvement in the tests.

Fourth, I am always amazed at the reluctance of some people to try out new ideas, especially when there is no risk of any kind involved. Several times Mr. Codomo has cordially invited Mr. Levinson to view the Cortical Hearing Aid in action, but Mr. Levinson has always refused. If he wishes to visit us at Biophysical Research sometime to witness tests, he will be most welcome.

CURTISS B. SCHAFER
Director of R & D
Biophysical Research, Inc.

DON'T FORGET AMBISONICS

TO THE EDITOR:

Re: Len Feldman's article "Sound with Images," May 1983. I believe any discussion on Surround Sound techniques (whether applied to disc, video, or FM/TV broadcasting) should at least make mention of the "Ambisonics

Altec	35
Alpha Audio	8
Amber	28
Ampex	Cover III, IV
Audio-Technica	21
BASF	9
Capitol Magnetic Prods.	13
Crown	5
David Hafler Co.	14
Design Direct Sound	38
Electro-Voice	31
Emilar	20
Garner	30
Gotham Audio	36-37
ITT Cannon	23
JBL	41
Klark-Teknik	6
Meyer Sound Labs	12
Orban	16
Otari	7, 25
PAIA	34
Polyline	34
Production EFX Library	48
QSC	26-27
Recording Studio Equipment Co. .	33
Renkus-Heinz	24
Rupert Neve	15
Saki Magnetics	22
Shure Bros.	Cover II
Sony	29
Standard Tape Lab	51
Studer Revox	11
Telex	19
Waters Mfg. Inc.	49
Yamaha	18

About The Cover

• This month's cover features Studio A of Sound Emporium Recording Studios in Nashville, Tennessee. Studio A features a Harrison 3232 AB console, 2-track and 24-track Studer tape machines, Sierra Monitors, and Altec, BGW, McIntosh, and Sony monitor amplifiers. Artists who have recorded in Studio A include Johnny Cash, the Marshall Tucker Band, and Kenny Rogers. The photograph was taken by John Fleming.



MORE RECORDING STUDIOS USE CROWN MONITOR AMPS THAN ANY OTHER BRAND.*

If you're going for gold, you've got to have the best – the best talent, the best writing, the best equipment. You'll leave nothing to chance.

That's why most studio professionals choose Crown monitor amplifiers.

They know they'll get the clearest highs, the most accurate mid-range, the most solid lows with Crown amps.

Sonic accuracy has always been the first goal – and the hallmark – of Crown engineering. Crown amps *are* powerful,

but never at the loss of sonic accuracy. Crown amps *are* reliable, but our first concern is sonic accuracy.

Crown amps will never get in the way of the music. With Crown, you'll know for sure when you've got a gold.



*See Billboard's International Recording Equipment & Studio Directory, 1982-1983.

1718 West Mishawaka Road, Elkhart, IN 46517 (219) 294-5571

Circle 13 on Reader Service Card

Sound System" developed with support from the National Research Development Corporation of Great Britain.

Ambisonics may be encoded using:

2 Channels—good Surround Sound;

3 Channels—the additional channel allowing a further improved illusion with sharper images;

2½ Channels—in practice, because the basic two channel version gives such good results, it is possible to obtain the further 3 channel improvements with only limited audio bandwidth (hence the additional ½ channel). In broadcasting, this extra ½ channel can, of course, be transmitted in a stereo multiplex signed by additional modulation of the 38 kHz sub-carrier;

4 Channels—for full-sphere reproduction including all angles of elevation and depression.

Needless to say all forms of encoding are totally mono/stereo compatible.

Ambisonic hardware not only includes the Calrec Ambisonic Sound-field microphone, but also the Abacoid Professional Decoder, the Audio + Design Professional Decoder, Transcoder, and (Multitrack) Pan Rotate units as well as various domestic decoders.

Further information can be obtained by contacting any of the manufacturers, including Audio + Design, P.O. Box 786, Bremerton, WA 98310 Tel: (206) 275-5009.

NIGEL BRANWELL
Vice President
Audio + Design Recording, Inc.

NOT SO DULL AFTER ALL TO THE EDITOR:

Enclosed is my check for three more years. If I found db "dull" (see our January editorial—Ed.), I wouldn't be renewing my subscription.

I don't find it too technical either. As for the reviews, I think they're very good. Ken Pohlmann did an excellent job in the March issue (on the MCI JH-800 console). If I only had the kilobucks, I'd buy one. However, don't forget the little guys either. Precision Electronics in Franklin Park, Illinois, has a new mixer coming out this fall. Maybe you could take a look at it.

I'll close by saying...you can't please everyone. Even the Good Lord couldn't do it.

Keep db coming!

HARVEY FULLINGTON
Oak Creek, Wisconsin

db replies:

Thanks for the kind words, Harvey. And we wouldn't dream of trying to please everyone. We've even stopped trying to please the publisher. As for Ken Pohlmann, he hasn't been pleased since we made him give back that console.

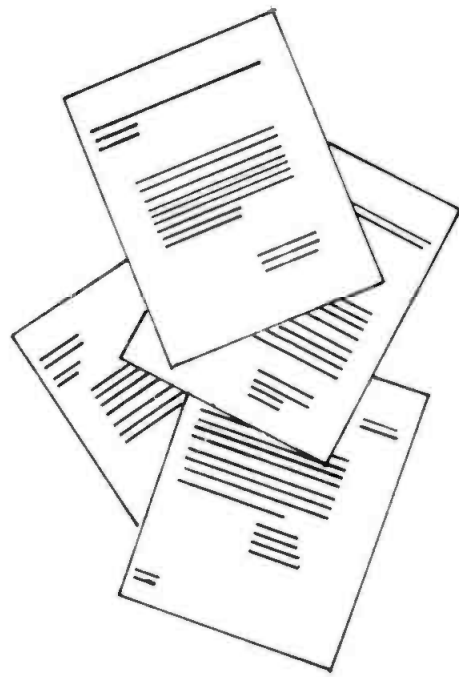

The next step in digital delay—434 m sec.

Introducing the DN700 from Klark-Teknik Research. This is the first of a new series of innovative microprocessor-controlled Digital Delay Lines with new and better price:performance ratio — bringing true professional performance in delay circuitry within reach of more users than ever before.

DN700 is a rack mounted 1-in 3-out unit giving easily adjusted delays up to 434 milliseconds, primarily for sound reinforcement applications. Features include non-volatile memory, an auto-diagnostic facility, and tamperproof lockout — with a minimum resolution of 26.5 microseconds.

Specification includes:

Frequency response +0.5 - 1.0dB
20Hz-15kHz

Dynamic range 20Hz-20kHz
(unweighted). Better than 85dB

Distortion (THD) @ 1kHz + 10dBm
<0.05% for any delay length.

The Klark-Teknik promise — a bigger investment in the future with:

1. Greater R&D investment, with 12% of all company personnel directly involved in new product development.
2. Consistent attention to production economies for professional performance at 'breakthrough' prices.
3. Effective 'Reliability Control' during manufacture.



KLARK TEKNIK



British designed, British made



Manufactured by Klark-Teknik Research Limited
Coppice Trading Estate, Kidderminster DY11 7JJ,
England. Telephone: (0562) 741515 Telex: 339821

Klark-Teknik Electronics Inc.
262a Eastern Parkway, Farmingdale,
NY 11735, USA. Telephone: (516) 249-3660
Circle 14 on Reader Service Card

Omnimedia Corporation Limited
9653 Côte de Liesse/Dorval, Quebec H9P 1A3,
Canada. Telephone: (514) 636 9971

TECHNOLOGY YOU CAN TOUCH

*The Otari MTR-10 Series
1/4" & 1/2" Mastering/Production Recorders*



The MTR-10 Series are fully microprocessor controlled mastering/production recorders available in four recording formats: 1/4" full-track; 1/4" two channel; 1/2" two channel and 1/2" four channel. They are the ultimate in analog tape recorder performance and are the embodiment of our dedication to innovation and quality. Practical, efficient and exclusive transport and electronic features abound. Unprecedented control and flexibility are now yours because they are the only mastering recorders in their class which feature an extremely sophisticated, full-function, ten memory locator. For the stringent requirements of multi-media production all versions of the MTR-10 Series machines easily interface with any SMPTE-based video editing system, machine controller or synchronizer.

Working closely with industry leaders in broadcast, film and recording production, we have engineered a recorder that is ready to meet any audio professional's challenge. Superb reliability, the hallmark of Otari's reputation, assures a professional's investment in today's business... secures it for tomorrow's.

The MTR-10's are engineered like no other tape machines in the world; with the qualities you can hear and feel.



OTARI Technology You Can Touch.
Otari Corporation, 2 Davis Drive, Belmont, CA 94002
Tel: (415) 592-8311 Telex: 910-376-4890



Circle 15 on Reader Service Card

©Otari Corporation, 1982

Come Help Us Celebrate The Child

St. Jude Children's Research Hospital continues its search for life-saving knowledge about childhood disease because people like you care. The cost of treatment, equipment and research programs is met primarily by public contributions.

Help us celebrate the children of the world with your check or request for further information to St. Jude, 505 N. Parkway, Memphis, TN 38105.



ST. JUDE CHILDREN'S RESEARCH HOSPITAL
Danny Thomas, Founder



Calendar

OCTOBER

Oct.- Sync-Aud-Con 2-day Audio Jan. Engineering Seminars. These seminars will be held throughout the country. For more information, contact: Synergetic Audio Concepts, P.O. Box 669, San Juan Capistrano, CA 92693. Tel: 714/496-9599.

3-7 Underwater Acoustics and Signal Processing Course. Sponsored by The Pennsylvania State University, University Park, PA. For more information, contact: Alan D. Stuart, Course Chairman, Applied Research Laboratory, The Pennsylvania State University, P.O. Box 30, State College, PA 16801. Tel: 814/865-7505.

9-12 74th Audio Engineering Society Convention. New York Hilton. For more information, contact: The Audio Engineering Society, 60 East 42nd Street, New York, NY 10165. Tel: 212/661-8528.

12-13 National Association of Broadcasters' 16th Annual AM Directional Seminar. Airport Marriott Inn, Cleveland, OH. For additional information, contact: Janis Shipe, NAB Science and Technology Department, 1771 N. Street, N.W., Washington, DC 20036. Tel: 202/293-3557.

17-24 Canadian Acoustical Association Annual Meeting and Symposium. Vancouver, B.C., Canada. For more information, contact: Canadian Acoustical Association, Box No. 46256, Postal Station G, Vancouver, Canada V6R 4G6.

SONEX users tell it like they hear it.



Presentation control room at Multi-Image Resources, Dallas TX; works "above reproach."



Control room and studio at Eastern Sound Studios, Methuen, MA.



Audio production facility, Larry Blakeney & Associates, Jackson, MS.



KLOR FM, Ponca City, OK; used to "reduce ambient noise and smooth out frequency response" in news studio.

Audio Visual Center, Hays, KS; "Great! Stopped reverberating sounds" in audio taping room.



Here are just five applications and comments from among our almost 2,000 SONEX users. Eastern Sound: "Our studio never sounded better and our control room is very accurate...". Blakeney: "SONEX controls acoustics beautifully, better than carpet, acoustic tile, or any other product... don't have to worry about outside noise... or disturbing our neighbors when we turn the volume up...". Klor also says that it is "critical in master tape work, and far superior to any other system we've tried."

Get the facts today. SONEX is manufactured by Illbruck/usa and distributed exclusively to the pro sound and A/V industries by Alpha Audio.

Alpha Audio

2049 West Broad Street
Richmond, Virginia 23220 (804) 358-3852
Acoustic Products for the Audio Industry

Circle 16 on Reader Service Card

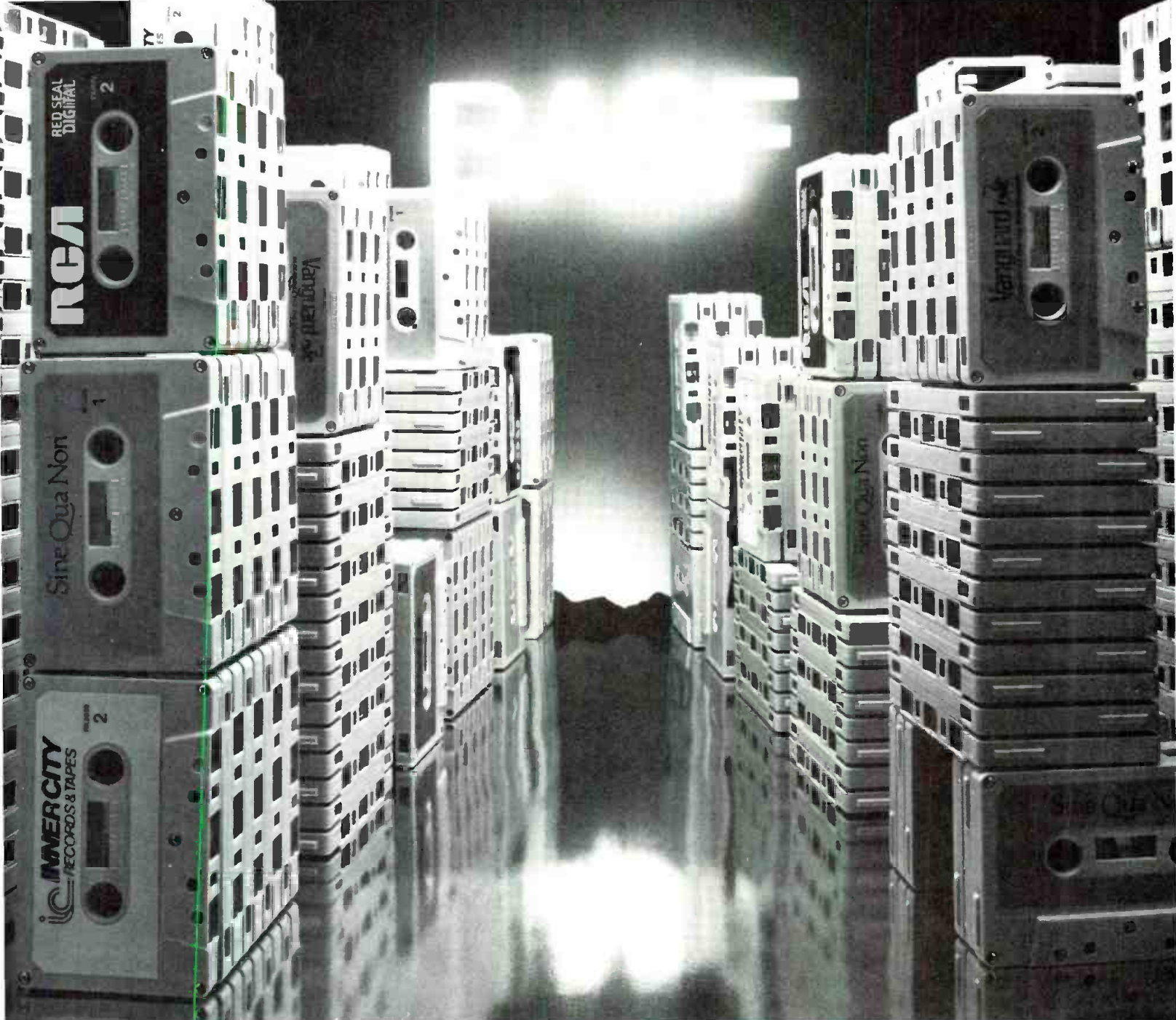

THE ROAD TO PLATINUM IS PAVED WITH BASF PURE CHROME.

The only place to be in the recording business is #1. And with cassettes taking over nearly 50% of the industry's pre-recorded sales this year, the best way to get to the top is on BASF Pure Chrome duplicating tape.

BASF Pure Chrome helps you climb the charts faster because it duplicates your sounds more perfectly than any other brand. Technically speaking, BASF Pure Chrome offers extended high frequency Maximum Output Level (MOL), plus the world's lowest background noise. And our exclusive Pure Chrome formulation is extremely clean and stable at even the highest duplicating speeds. The payoff? Audio performance that's virtually indistinguishable from a studio master recorded at 15 I.P.S.



Best of all, just about anyone can change over from ferric oxide to BASF Pure Chrome with the greatest of ease—and without any need for additional equipment or expenses.

Find out why such major names as RCA Red Seal Digital, Sine Qua Non, Vanguard and Inner City all put their trust in us. Switch to BASF Pure Chrome duplicating tape. Because when you put "CrO₂" on your label, you're not just guaranteeing the public the pure music they're paying for. You're paving your way to platinum with BASF Pure Chrome.



Circle 17 on Reader Service Card

Theory & Practice

Roll Over Helmholtz

• We all have our little idiosyncracies—the things that make us a little eccentric. We try to hide them, but sometimes it's just too much. Especially insidious are the little things that make us lose our temper. I confess that there are a number of things that really tick me off. One of them occurs all too often in audio literature. Maybe it's my kinship with my German heritage, maybe it's because I used to go out with Jennifer Helmholtz (Jenny, if you're reading this, all is forgiven, please come back), or maybe it's my educator's crusading spirit against ignorance. Whatever the reason, I've always held a special admiration for the great German physicist, anatomist, physiologist and epistemologist Helmholtz, and a special distaste for anyone who misconstrues, mis-states, or otherwise botches up an explanation of the resonator which bears his name.

WRONG!

That peeve isn't as obscure as you might think. I've been loosely keeping track, and over the years I've seen over a dozen mythical explanations of how a Helmholtz resonator works. I've heard it explained as a "vacuum pocket at the mouth of an air cavity," "a resonator which has been tuned to absorb," "the same as a violin body, without the strings," "standing waves in a volume approximately the size of a beer bottle," and other highly speculative propositions. Recently, in a highly respected audio magazine (not *db*, thank goodness) a slot absorber was explained as "sympathetically vibrating wood slats absorbing troublesome modes." Even in "The Literature," supposedly authoritative texts on acoustics, there are slight yet disconcerting disagreements in formulas presented to explain resonators. In all fairness, the apparently simple resonator conceals a lot of difficult theory and even today the exact mathematics remain incomplete.

SOME HISTORY

Even without all the math, ancient acousticians recognized the utility of resonators and incorporated them into the design of their theatres; Roman engineer Marcus Vitruvius Pollio describes the use of bronze vessel resonators in Greek open air amphitheatres, and cavity resonators are still to be seen in ancient Roman ruins, constructed in niches between the seats. Resonators made of clay were used in Swedish churches nearly a thousand years ago to improve the acoustics. But it was Helmholtz, Hermann Ludwig Ferdinand von Helmholtz to be exact, who identified and quantified the mechanism of cavity resonators. He presented the first accurate explanation of resonators in his famous treatise, "On The Sensations of Tone (1863)"; his theory was later expounded upon by Lord Rayleigh in *The Theory of Sound* (1877). Although both of these volumes and their explanations of resonators are heavy reading, the bottom line is familiar to most musicians and all beer drinkers who know that a resonance can be excited by blowing across the mouth of the volume.

Helmholtz found that the secret lies in the air in the neck; it oscillates as a single mass, and the large cavity of air provides a restoring force. The most convenient model is a mass and spring, but in reality both components are comprised of air. If the neck is plugged and air is pumped into the volume, and then the neck is suddenly unplugged, air will rush from the volume to attempt to equalize the pressure. However, the air's momentum will carry it too far, resulting in lower air pressure inside the volume. The air will rush back, but again momentum will result in an imbalance and the damped oscillation continues. The larger the volume, the more excess air pressure it can hold for a given excess pressure, so the oscillations are slower, resulting in a slower frequency of vibration. The larger the

air mass in the neck (for example, a longer neck), the lower the resonant frequency. But a larger cross-sectional area in the neck lets the air flow faster, so the oscillations are quicker. Thus the frequency is increased.

Helmholtz used the resonator as a means of analyzing complex sounds. He constructed a series of graduated resonators covering a wide frequency range and used them in his investigations of complex tones; a resonator will respond to and amplify its resonant frequency when that frequency is present in a complex tone; by attaching an earpiece, a primitive analyzer is obtained.

In terms of acoustical treatment, Helmholtz found that incident sound energy is absorbed in a region centered at the resonant frequency. Some energy is dissipated as heat because of the frictional resistance of the oscillating air flow in the neck. If the inside of the neck is roughened, the frictional loss is increased, and the resulting amplitude at the resonant frequency will be lower. In addition to viscosity losses, there are also radiation dissipation losses to the surrounding medium.

SLOT ABSORBERS

Although we've devised more sophisticated methods to analyze complex tones, Helmholtz's resonator discovery still remains a useful member of the acoustician's repertoire of acoustic solutions. As we've already mentioned, cavity resonators have been around for two millenia, but a variation on the simple resonator appears in many contemporary studios in the guise of the slot absorber. This resonator may be constructed close to a wall and occupies only a reasonable amount of depth. Most important, that loss of sound energy at the opening of the mouth accounts for the resonator's ability to absorb a room's eigen frequencies—

Studer Re-States the Art

With the new A810, Studer makes a quantum leap forward in audio recorder technology. Quite simply, it re-states the art of analog audio recording.

By combining traditional Swiss craftsmanship with the latest microprocessor control systems, Studer has engineered an audio recorder with unprecedented capabilities. All transport functions are totally microprocessor controlled, and all *four* tape speeds (3.75 to 30 ips) are front-panel selectable. The digital readout gives real time indication (+ or - in hrs, min, and sec) at all speeds, including vari-speed. A zero locate and one autolocate position are always at hand.

That's only the beginning. The A810 also provides three "soft keys" which may be user programmed for a variety of operating features. It's your choice. Three more locate positions. Start locate. Pause. Fader start. Tape dump. Remote ready. Time code enable. You can program your A810 for one specialized application, then re-program it later for another use.

There's more. Electronic alignment of audio parameters (bias, level, EQ) is accomplished via digital pad networks. (Trimpots have been eliminated.) After programming alignments into the A810's memory, you simply push a button to re-align when switching tape formulations.

The A810 also introduces a new generation of audio electronics, with your choice of either transformerless or transformer-balanced in/out cards. Both offer advanced phase compensation circuits for unprecedented phase linearity. The new transport control servo system responds quickly, runs cool, and offers four spooling speeds.

Everything so far is standard. As an option, the A810 offers time-coincident SMPTE code on a center track between stereo audio channels. Separate time code heads ensure audio/code crosstalk rejection of better than 90 dB, while an internal digital delay automatically compensates for the time offset at all speeds. Code and audio always come out together, just like on your 4-track. Except you only pay for 1/4" tape.

If you'd like computer control of all these functions, simply order the optional serial interface. It's compatible with RS232, RS422, and RS422-modified busses.

More features, standard and optional, are available. We suggest you contact your Studer representative for details. Granted, we've packed a lot into one small package, but ultimately you'll find that the Studer A810 is the most versatile, most practical, most *useable* audio recorder you can buy.

The Swiss wouldn't have it any other way.



STUDER REVOX
PRECISION FROM SWITZERLAND

Studer Revox America, Inc. • 1425 Elm Hill Pike, Nashville, TN 37210 (615) 254-5651
Offices: Los Angeles (213) 780-4234 • New York (212) 255-4462 • Dallas (214) 760-8647 • Canada: Studer Revox Canada, Ltd.

Circle 18 on Reader Service Card

www.americanradiohistory.com

either with a narrow or wide band characteristic. A number of configurations are possible, but the basic design calls for a series of wood slats laid in parallel in a plane, and angled from the rear wall. The approximate frequency of resonance is determined by the volume:

$$f = \frac{c}{2\pi} \sqrt{\frac{A}{dV}}$$

- where c = velocity of sound,
- A = area of slat,
- d = thickness of slat,
- V = volume between slat and wall.

The absorption characteristic may be varied in a number of ways; a sound absorbing blanket placed in the air gap behind the slats dampens the resonant response and broadens its bandwidth. Moreover, there is an improvement in absorption at oblique incidence, especially as the amount of filling increases to effectively decouple the individual slots. For maximum effect, the porous material should be placed at the front of the gap (next to the slats) where the air particle velocity is at its maximum. Building with non-uniformly spaced and non-uniformly dimensioned slats also broadens the characteristic. Careful attention must be paid to the dimensioning behind the slats: the phase of the wave reflected from the rear wall,

as it returns to the mouth of the slot, will affect absorption. The air space behind the slats can be partitioned to form smaller volumes with inversely higher resonant frequencies. Slot absorbers are one of the most effective kinds of resonators, and it is perhaps slightly magical to observe the acoustic results in a room tuned with this kind of construction. But far from being magic, some highly interesting theory underlies its operation.

THE HELMHOLTZ RESONATOR

A Helmholtz resonator is a simple type of resonator: it is an enclosed volume with an opening to the outside medium. Specifically, it is a system with one degree of freedom and as such has a characteristic response common to all acoustic, electrical, or mechanical systems with one degree of freedom. In fact, the underlying mathematics is identical for each of these types of systems. Acoustic inertance, compliance, and resistance form an analog with electrical inductance, capacitance, and resistance, and with mechanical mass, compliance, and resistance. For example, we can draw a Helmholtz resonator in terms of either of its acoustic or electrical driven oscillator analogues, as seen in FIGURE 1.

In its acoustic model, the plug of air

in the mouth is the mass element, internal pressure is stiffness or compliance, and radiation dissipation and viscosity provide resistance. Given these elements, appropriate formulas may be derived. We may define the acoustic inertance M of the acoustic element as follows:

$$M = \frac{m}{S^2}$$

where m = effective mass of the element,

S = area of opening.

This leads to the empirical approximation for the Helmholtz resonator, which is determined by the formula:

$$M \cong \frac{\rho_0(l + \sqrt{S})}{S}$$

where ρ_0 = density of air,

l = depth of opening.

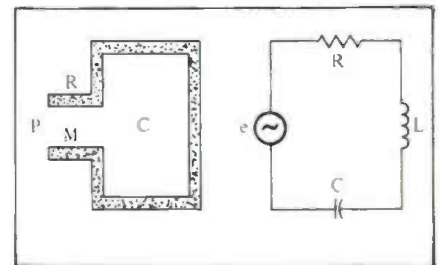

Figure 1. The acoustic and electrical analogs of a Helmholtz resonator.

The control electronics behind the 833 Studio Reference Monitor System

Meyer Sound's 833 Studio Reference Monitor System is standardised for consistent response — giving a growing number of professional engineers and producers more creative control. The C833 controller shown regulates frequency and phase response, and has Meyer's exclusive Speaker Sense™ circuitry to prevent driver overload. The 833 handles up to 400W, with power and headroom that lets you feel the full effect of the music — and performs consistently for longer

than previous speaker designs. Effectively linear time response and improved 'coherence'* ensure clear and controllable stereo imaging.

*See our new brochure on the 833.

To see the difference in our speakers, or hear the difference in our system — see us at AES in New York — or contact Meyer Sound.



Meyer Sound Laboratories Inc.
2194 Edison Avenue, San Leandro,
California 94577, USA.
Telephone: (415) 569-2866

Circle 19 on Reader Service Card

"I prefer Apollo Master blanks for my most critical work."

Vladimir Meller

Custom Mastering Engineer
Columbia Records Mastering Studios,
New York City



"I believe they give as quiet a cut as you can get through conventional mastering."

"The Apollo has all the pluses mastering engineers look for."

We designed into the Apollo lacquer all the features the mastering engineers have been asking for: better flatness, less noise, clean cutting, longer stylus life, better uniformity and consistency. Ultimately, the Apollo results in better records.

"Absolutely flat."

All aluminum blanks used for the Apollo are micropolished using a process originally developed for magnetic computer disks. This multi-step process resurfaces the aluminum blanks and creates a fine finish, free from defects and with an improved flatness.

"Free of ticks and pops."

Our elaborate lacquer manufacturing process insures that all particles and gels which could cause cutting problems are removed. Moreover, the new formulation resists lacquer buildup on the stylus, thus reducing groove wall scoring and loose debris in the groove, which contribute to ticks and pops.

"Least abrasion."

The unique Apollo formulation reduces the cutting friction when contacted by the heated stylus. This results in lower abrasion, thus extending the stylus life. And, of course, the formulation does not use any abrasive ingredients in the first place.

"Very consistent from batch to batch."

The excellent consistency of the Apollo lacquer masters is the result of complete control we have over the critical raw materials and the blending of the formulation. In addition, the extensive process and quality control methods assure the maintenance of tight manufacturing tolerances.



We've Mastered the Master.

Capitol
APOLO
Master Audiodisc.

Capitol Magnetics Products, 6902 Sunset Boulevard, Hollywood, CA 90028.

© 1983 Capitol Magnetic Products. A division of Capitol Records, Inc. All Rights Reserved.

Circle 20 on Reader Service Card

In the same way that electrical capacitance is defined as the charge per unit of applied voltage, the acoustic compliance C of an acoustic element is defined as the volume displacement produced by the application of unit pressure, and may be determined by the formula:

$$C = \frac{V}{\rho_0 c^2}$$

where V = volume of enclosure,
 c = velocity of sound.

The dissipation of energy at the resonator mouth is analogous to electrical resistance. Considering the dissipation due to radiation from the mouth, we obtain:

$$R = \frac{\rho_0 \omega^2}{4\pi c}$$

where $\omega = 2\pi f$

The resonant frequency occurs when the acoustic reactance is equal to zero, determined as follows:

$$\omega M - \frac{1}{\omega C} = 0$$

Thus the resonant frequency is equal to:

$$\omega = \sqrt{\frac{1}{MC}}$$

Furthermore, the Q of the resonant response of a Helmholtz resonator is theoretically given by:

$$Q = \frac{\omega M}{R}$$

And Helmholtz's equations don't end with slot absorbers and beer bottles; the theory may be applied throughout acoustic design. For example, a loudspeaker in a cabinet may be treated as a Helmholtz resonator with an inductance comprised of both the reactance of the enclosing air and the speaker cone mass. The effective compliance is similarly the sum of the stiffness of the enclosed air and the cone suspension. The acoustic resistance is the sum of radiation and viscosity losses, and speaker cone mechanical resistance.

Mathematics and patient explanations are all well and good, but so far we've managed to dodge the real issue. The essence of the resonator's operation still remains to be revealed. Consider the sleight of hand which has occurred. First we explained that Helmholtz used resonators to apparently amplify tones within complex sounds, then we told how resonators apparently soak up tones. Consider the following experiments: Hold a tuning fork over a tube partly filled with water

and vary the water level until the distance from the water to the top of the tube equals one quarter the wavelength of the tuning fork's frequency. The sound from the tuning fork will get *louder*. Is this the kind of absorber to use in studio design? Helmholtz's secret is wildly unique.

THE MAGIC REVEALED

The general phenomenon of resonance refers to the excitation of a vibration in a body by a wave from another source. The phenomenon is most obvious when the driving frequency equals the natural frequency of vibration of the resonator, as in the case of a tenor shattering a glass. In fact, we are tempted to suppose that a resonator can amplify the flow of sound energy after it has left its source. Unfortunately, neither that nor perpetual motion machines are possible; rather, a resonator may increase the flow of energy that is becoming available as sound, but it can never multiply the flow of sound already present. A resonator can cause a source to emit more sound energy (as in musical instruments) because of the changed phase relationship of the velocity and pressure at the source. Consider the analogous case of a pendulum in motion. If force is applied in phase with the maximum velocity, the energy of the system is increased. Of course, an unfavorable phase relationship would result in decreased system energy. The latter is one of the secrets of the Helmholtz resonator. The characteristic behavior of a small pressure at the neck producing large mass fluctuations can be exploited to effectively decrease acoustic energy near the resonant frequency.

The geometry of a Helmholtz resonator creates that characteristic behavior because it differs from any other design. An open pipe is a simple resonator, but with a Helmholtz there is a change in the cross section, and the small orifice acts to contain energy in the enclosed volume and create a unique "conductivity," as Rayleigh called it. The conductivity determines the extent of the air which vibrates; the value of conductivity varies with the mechanism acting at the orifice. Conductivity depends upon the viscous resistance of the orifice (as when a porous blanket is present) or upon the radiation resistance of the orifice. Thus a Helmholtz resonator design, and the resulting conductivity, determines whether it acts as a diffuser or an absorber, or a combination of the two. If there are no viscous or thermal losses, the action consists in storing sound energy in its internal vibration and diffusing incident sound as an out-of-phase point source. This storing up of energy accounts for the decrease in instantaneous sound energy; when the incident sound ceases, resonance ceases.

**QUALITY
RELIABILITY
VERSATILITY**

The David Hafler Company has earned a reputation for producing state of the art power amplifiers at rock bottom prices. The Hafler DH-220 and DH-500 Amplifiers are well known for their sound quality, reliability and value.

Now, there's the P-500! The P-500 is a rugged, full-featured amplifier. It combines the circuit design and MOSFET output devices of the DH-500 with extra professional features; an automatic 3-speed fan, barrier strip, phone plug and XLR connectors, balanced or unbalanced inputs and gain controls, to name just a few. And like other Hafler products, the P-500 is available in fully or partially assembled form.

For a complete list of features and specifications, write to:

hafler

**The David Hafler Company
Dept. DS, 5910 Crescent Boulevard
Pennsauken, New Jersey 08109**





Capture sound at its purest.

Hold a seashell to your ear and hear nature's pure and natural sound. Compare it to the final sound produced by a Neve. You'll begin to understand why Neve is far and away the most respected name in audio mixing.

The Neve sound is so pure and natural, one might suspect that nature herself had a hand in the design. Perhaps.

Not every engineering achievement can be explained away. There are mysteries in nature, just as there are mysteries man-made.

Some suggest that Neve's unique Formant Spectrum Equalizers account for its unparalleled sound by taking into account the psycho-acoustic properties of voice and music while satisfying the critical demands of balance engineers. Others claim it's superior technical performance, novel circuitry, or high quality components.

All agree on one thing: To capture sound at its purest, aspire to Neve.

For further information, call us, or write.

Aspire to Neve

RUPERT NEVE INCORPORATED: Berkshire Industrial Park, Bethel, Connecticut 06801 (203) 744-6230 Telex 969638 • 7533 Sunset Blvd., Hollywood, California 90046 (213) 874-8124 Telex 194942 • RUPERT NEVE OF CANADA, LTD. represented by: Manta Electronics Group, 204 King St. East, Toronto, Ontario M5A 1J7 Canada (416) 868-0513 Telex 06-986766 • Sonotechnique, 2585 Bates, Suite 304, Montreal, P.Q. H3S 1A9 Canada (514) 739-3368 Telex 055-62171

NEVE ELECTRONICS INTERNATIONAL, LTD: Cambridge House, Melbourn, Royston, Hertfordshire, SG8 6AU England Phone (0763) 60776

RUPERT NEVE GmbH: 6100 Darmstadt Bismarckstrasse 114, West Germany Phone (06151) 81764.

Circle 21 on Reader Service Card

and the energy is bled back to the system. Viscous losses are also present, always as air particle friction at the high-velocity orifice or as introduced porous absorbers within the resonator. Increasing the amount of porous material dampens the vibration of the absorber and lessens the selectivity of the resonator. When conductivity is equal to unity, there is an approximate equality between viscosity and diffusion losses. A larger conductivity favors diffusion losses and yields a more selective characteristic. Unfortunately, precise calculations for conductivity are almost impossible for practical applications because of the complexity of the acoustics at the mouth of the resonator. That's why you hire an acoustician instead of buying a calculator.

For demonstration purposes only, we'll attempt a practical design—one full of approximations. Using our new-found conductivity element, we can write the formula describing the natural frequency of a volume resonator having a circular orifice as:

$$f = \frac{c}{2\pi} \sqrt{\frac{K}{V}}$$

where K = conductivity,
V = volume of resonator,
c = velocity of sound.

If we ignore the thickness of the resonator's material (i.e. the orifice has no neck length), the value for k is twice the radius of the cylindrical volume. Let's compare the resonating properties for a simple open end pipe with the closed resonator at a frequency of 440 hertz. A pipe of cross-sectional area of 10 square centimeters would require a length of one fourth the wavelength of 440 hertz, or 18.8 centimeters. If we build a Helmholtz with a closed top and circular orifice of 1.0 centimeter in diameter, our formula produces a length requirement of 14.4 centimeters. Encouraged by our success, suppose we design a Helmholtz resonator with a neck 2.0 centimeters long and 1.0 centimeter in diameter. Using a new approximation for conductivity,

$$K = \frac{\pi r^2}{l = \pi r/2}$$

where r = radius of orifice,
l = radius of neck,

we find that our 440 hertz resonance is achieved in a resonator only 4.1 centimeters high. More than anything else, that demonstrates the efficiency of the Helmholtz design and its ability to secure low frequencies with a small air volume. Now you know why we can sing a pitch which otherwise requires

a ten foot organ pipe to produce. And can you explain why the resonator in your throat produces bass notes, while the one on your studio wall absorbs them?

The applications of Helmholtz's resonator theory are endless, and so is the complexity of the math, but I hope we've shed light on the basic idea—at least enough illumination for me to give you fair warning. In the future, I will not tolerate any more ridiculous explanations of Helmholtz resonators. If I catch anyone at it, I'll print their names and addresses. Poor von Helmholtz has been rolling around in his grave long enough; let the old guy rest in peace.

I'm glad we settled that. Now I want to speak with all you guys who put those plastic things in your shirt pockets and cram them with mechanical pencils and Bic pens. Do you have any idea how dumb that looks? You've given engineers an image problem that they'll never live down. I mean, it really ticks me off... ■

REFERENCES

- Olson, H. F., *Music, Physics and Engineering*, Dover Publications, 1967.
Richardson, L. R., *Technical Aspects of Sound*, Elsevier Publishing, 1953.
Stewart, G. W., *Introductory Acoustics*, Van Nostrand, 1940.



It speaks for itself.

We thought about hiring an expensive superstar to extoll the virtues of the famous Orban 622B Parametric EQ. After all, there are 622B's backing up superstars worldwide in recording studios, arena shows, broadcast facilities... you name it! But we decided not to. Because ultimately, the Orban 622B speaks for itself—it's the most widely used, popular professional Parametric in the world.

The 622B combines full, four-band Parametric equalization with tunable notch filtering to offer extraordinary versatility and control. Our "constant-Q" design provides -40dB attenuation while allowing gentle, musically-useful broadband EQ too. This makes the 622B ideal for critical sound reinforcement chores as well as studio production work.

Call your local Orban dealer for further information.

orban Orban Associates Inc. 645 Bryant St.
San Francisco, CA 94107 (415) 957-1067
TLX: 17-1480

Circle 22 on Reader Service Card

And now
a
message
on
Yamaha's new
RM1608
recording
mixer.

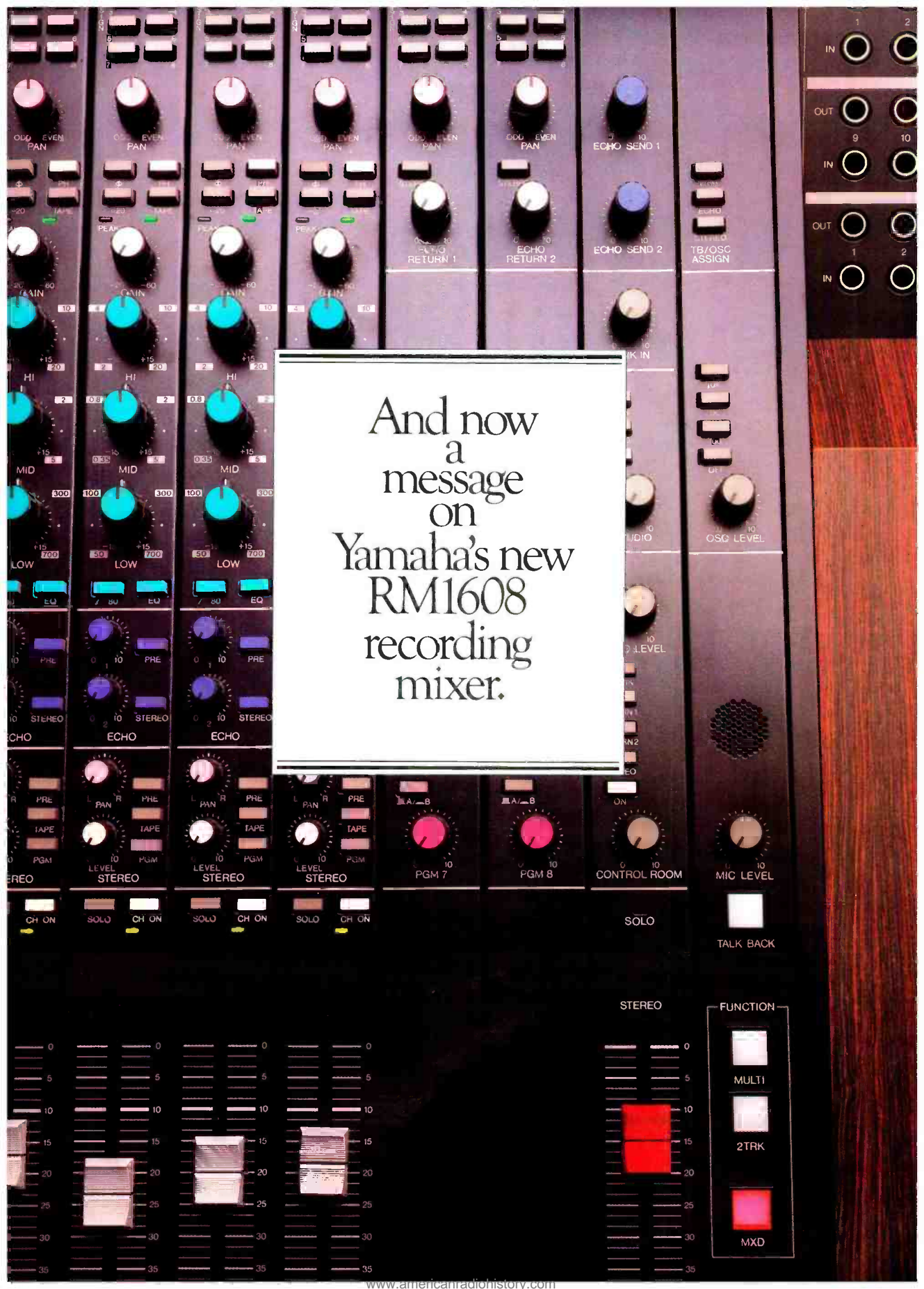



RM1608

SPECIFICATIONS

TOTAL HARMONIC DISTORTION (T.H.D.)

Less than 0.1% at +4dB *output, 20Hz to 20kHz (all Faders and controls at nominal)

HUM & NOISE (20Hz to 20kHz) $R_s = 150$ ohms (INPUT GAIN "-60")

- 128dB Equivalent Input Noise (E.I.N.)
- 95dB residual output noise: all Faders down.
- 80dB (84dB S/N) PGM Master volume control at maximum and all CH PGM assign switches off.
- 64dB (68dB S/N) PGM Master volume control at maximum and one CH Fader at nominal level.
- 73dB (77dB S/N) STEREO Master Fader at maximum and all CH STEREO level controls at minimum level.
- 64dB (68dB S/N) STEREO Master Fader at maximum and one CH STEREO level control at nominal level.
- 80dB (70dB S/N) ECHO SEND volume at maximum and all CH ECHO volumes at minimum level.
- 75dB (65dB S/N) ECHO SEND volume at maximum and one CH ECHO volume at nominal level.

CROSSTALK

- 70db at 1kHz: adjacent Input.
- 70db at 1kHz: Input to Output.

MAXIMUM VOLTAGE GAIN (INPUT GAIN "-60")

PGM	74dB: MIC IN to PGM OUT.	ECHO	70dB: MIC IN to ECHO SEND.	
	24dB: TAPE IN to PGM OUT.		C/R	74dB: MIC IN to C/R OUT.
	34dB: ECHO RETURN to PGM OUT.		STUDIO	24dB: 2 TRK IN to C/R OUT.
	14dB: PGM SUB IN to PGM OUT.			74dB: MIC IN to STUDIO OUT.
STEREO	74dB: MIC IN to STEREO OUT.		24dB: 2 TRK IN to STUDIO OUT.	
	24dB: TAPE IN to STEREO OUT.			
	34dB: ECHO RETURN to STEREO OUT.			

CHANNEL EQUALIZATION

± 15 dB maximum

HIGH: from 2k to 20kHz PEAKING. MID: from 0.35k to 5kHz PEAKING. LOW: from 50 to 700 Hz PEAKING.

HIGH PASS FILTER - 12dB/octave cut off below 80Hz.

OSCILLATOR Switchable sine wave 100Hz, 1kHz, 10Hz

PHANTOM POWER 48V DC is applied to XLR type connector's 2 pin and 3 pin for powering condenser microphone.

DIMENSION (W x H x D) 37-1/2" x 11" x 30-1/4" (953 mm x 279.6 mm x 769 mm)

Hum and Noise are measured with a -6dB/octave filter at 12.47kHz; equivalent to a 20 kHz filter with infinite dB, octave attenuation.

*0dB is referenced to 0.775V RMS.

• Sensitivity is the lowest level that will produce an output of -10dB (245mV), or the nominal output level when the unit is set to maximum gain.

• All specifications subject to change without notice.

The specs speak for themselves. But they can't tell you how natural, logical and easy the RM1608 is to work. All the controls and switches are logically arranged to help you get the job done quickly and accurately.

And in the tradition of Yamaha's sound reinforcement mixers, the RM1608 sets new standards of reliability as well as ease of operation. For complete information, write: Yamaha International Corporation, P.O. Box 6600, Buena Park, CA 90622. In Canada, Yamaha Canada Music Ltd., 135 Milner Ave., Scarborough, Ont. M1S 3R1.



Circle 23 on Reader Service Card

Sound With Images

VHS Plays Audio 'Catch-Up' With Beta

A few months ago in this column I described a method of two-channel audio recording that was developed by Sony Corporation as a high-fidelity audio system for use with their Beta-format video recorders. The system successfully nestles a pair of frequency-modulated carriers between the chrominance and luminance video signals, applying these extra carriers to the magnetic tape medium via the same fast-spinning video heads which lay down the video signals. Since describing that system, I have had an opportunity to test the first Beta HiFi VCRs and can attest to the fact that performance equals or exceeds that obtained using the very finest analog, reel-to-reel professional tape decks without added noise reduction. Specifically, wow-and-flutter is reduced to a negligible and inaudible 0.005 percent, distortion is of the order of 0.3 percent

and frequency response is ruler-flat from 20 Hz to 20,000 Hz. With a system such as this, one wonders just how much of an advantage true digital recording offers when you consider that the cost of a Beta HiFi VCR is far less than even a minimum-featured PCM processor plus a conventional VCR which would have to be added to it as a tape transport.

Sony's aim (and the aim of other manufacturers licensed to produce Beta format VCRs) in introducing Beta HiFi was to capture a larger share of the VCR market which, over the years since the introduction of the original Betamax VCRs, has drifted more and more towards the VHS type of VCR. VHS recorders were developed a year after Beta by Victor Company of Japan (known here as JVC), and outsell Beta format machines by a factor of around 7 to 3 in the United States. Since the

audio quality of conventional Beta machines and currently available VHS machines is inferior to that of the lowest quality home audio cassette recorder, the developers of Beta HiFi felt that by offering improved audio second only to digital recording, they could significantly increase their market share. Furthermore, because of the specific baseband frequency assignments used in VHS recorders, supporters of the Beta system were convinced that the VHS folks would simply not be able to "squeeze in" an extra pair of FM carriers with the video signals, using the video heads, because of the particular arrangement of the video signal frequencies themselves in the VHS format. If they tried it, said the Beta people, they would have to degrade picture quality or make the new VHS format incompatible with older machines and tapes.



UNCOMPROMISING WIRELESS MICROPHONES

Finally, you can choose a wireless mic to fit the application. The Telex WHM-300, the electret wireless transmitter mic for uncompromising speech clarity. Or a Telex WHM-400 dynamic wireless transmitting mic for vocal entertainment with rich, full bodied audio quality. Both elegantly tapered and without trailing antenna wires. Or select the miniature electret WLM-100 lavalier mic (or any standard dynamic mic) with our belt-pack transmitter.

Combined with the superb Telex dual diversity* FM receiver, you'll have a wireless system that is as good as any hard wired mic, and at a reasonable price. Write us today for full details.



Quality products for the Audio Professional

TELEX

TELEX COMMUNICATIONS, INC.

9600 Aldrich Ave. So., Minneapolis, MN 55420 U.S.A.
Europe: Le Bonaparte Office 711, Centre Affaires Paris Nord, 93153 Le Blanc-Mesnil, France

*U.S. Patent No. 4293955. Other patents applied for.

Circle 24 on Reader Service Card

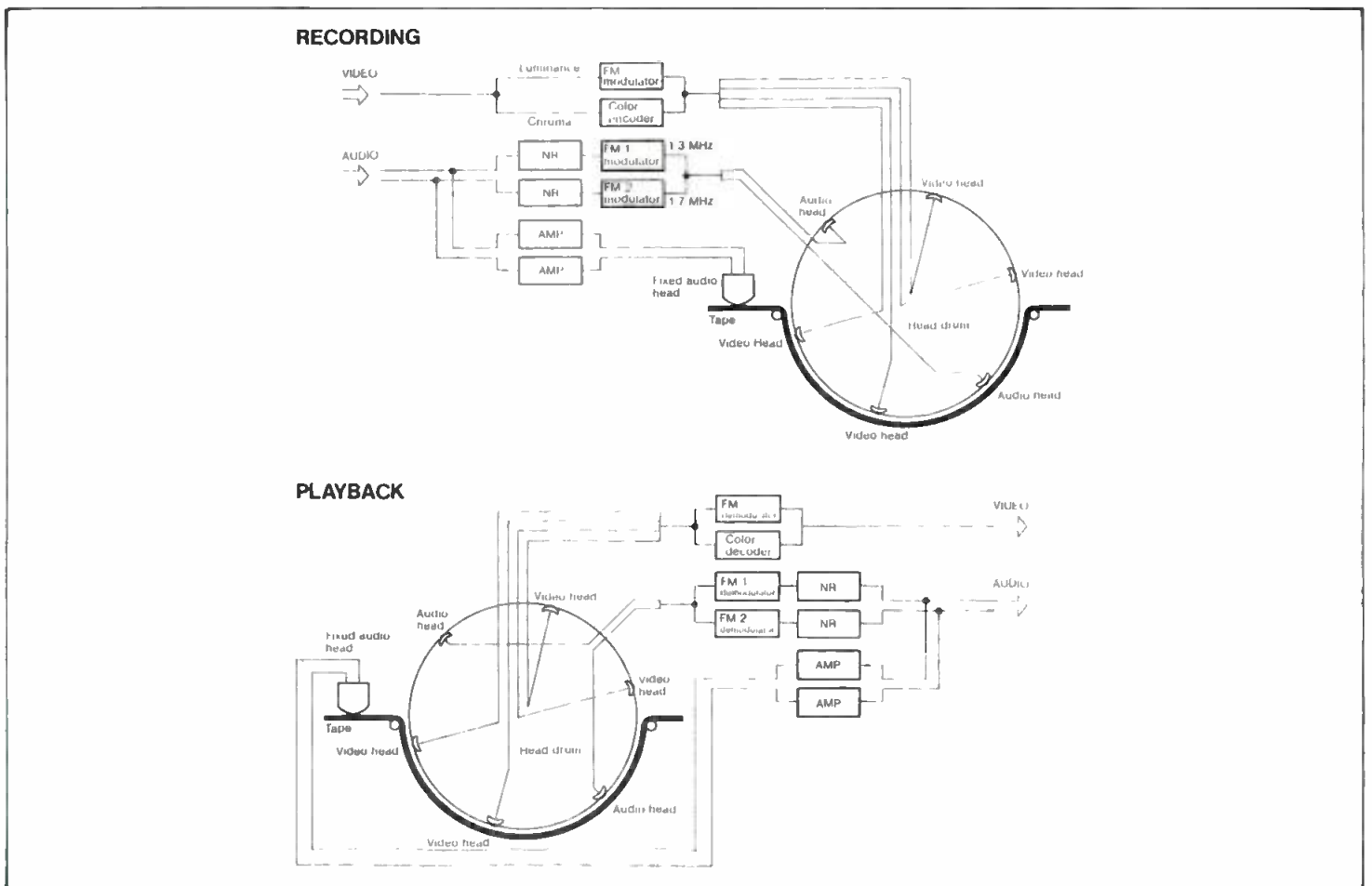

Figure 1. Separate audio heads are added to the spinning head-drum in JVC's newly developed VHS HiFi System of stereo audio recording for video. Fixed stereo audio head is retained for compatibility.

Proven Performers. Improved.

EMILAR

1365 N. McCan St. • Anaheim, CA 92806 • 714.632.8500 • 800.854.7181 • TWX 910.591.1191

VHS DOES IT TOO—BUT SOMEWHAT DIFFERENTLY

The history of home video recording, as you can see, has been one case of "catch-up" after another. In 1976, just a year after Sony Corporation introduced their first Betamax home video cassette recorder, JVC introduced the first VHS machine which permitted two hours of continuous video recording as opposed to Beta's one-hour recording capability. It wasn't too long after that the Beta camp introduced the Beta II format, which permitted a total of three hours of recording. The VHS adherents soon followed through with their LP speed (four hours of recording), after which Beta format machines introduced Beta III recording, with its five-hour recording capability. This was followed by the VHS introduction of the EP (or SLP speed), which offered six hours of recording and, when T-160 tapes were introduced, even eight hours of uninterrupted recording and playback.

As everyone expected, JVC's research department wasn't ready to concede defeat. And at the recently concluded Consumer Electronic Show in Chicago they revealed the details of their own VHS HiFi system which had been demonstrated even earlier in Tokyo. Having listened to the new system, and watched video picture reproduction accompanying the sound, I can attest that VHS HiFi not only

Now your ENG units can afford the same "line" microphones bought by every major network!

You can pay as much as \$1,500 or more to get a good long-reach line microphone. Or, you can put the new Audio-Technica AT815 in every production unit for under \$230 each, or the phantom-powered AT815R for under \$300 each.

What you'll hear is performance closely rivalling our more expensive brethren. So close, in fact, that every major network has tried and bought our line microphones. And you'll get some advantages which can be very important in the field.

For instance, the phantom-powered AT815R can interface with supply voltages from 9 to 52 volts without adapters or extra circuits. So you don't have to rebuild present equipment to put it on the air. We also have a neat 2-battery 9V power supply you can use. When one battery is in use, the other is on standby. For your peace of mind.

Our internal-battery AT815 uses a standard AA "penlite" cell available everywhere. And in intermittent use, a premium battery should last about 4,000

hours. That's over a year even if used eight hours every day! Just one less thing to worry about when time is short.

The AT815 and AT815R weigh barely over 9 ounces, to make them easy to "fishpole" or hand hold. And each comes with a foam windscreen which slips on in a second. Our optional shock mount can be added as well. And the AT815R has a bass roll-off switch if needed to control rumble.

Both models are designed to take the rough-and-tumble life of an ENG unit or remote film crew, and keep delivering excellent sound. With the narrow directivity which makes line microphones so useful in suppressing noise and "reaching out" beyond normal mike range.

If you thought line microphones were out of reach of your budget, ask your Audio-Technica sound specialist to show you the AT815 or AT815R. We think you'll agree that the networks are onto something great!

**AT815R Phantom-Powered
Line + Gradient Microphone.
Under \$300.**

**AT815
Line + Gradient
Microphone.
Under \$230.
Optional
shock mount extra.**

**AT8410a Shock
Mount. Under \$40.**

**AT8501 9V Dual Battery
Power Supply. Under \$100.**



audio-technica®

AUDIO-TECHNICA U.S., INC., 1221 Commerce Dr., Stow, OH 44224 216/686-2600

See us at AES Booth 158-159

Circle 26 on Reader Service Card

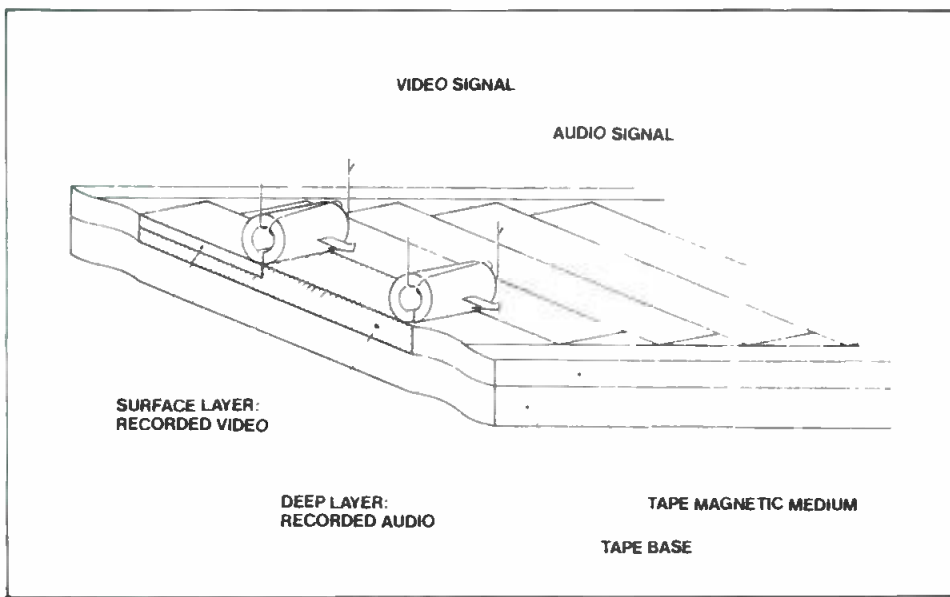

Figure 2. FM audio signals are recorded to full depth of the tape's magnetic medium and video signals are then recorded on the surface layer.

works magnificently, but that it does not noticeably degrade picture quality in any way.

EXTRA HEADS AND DEPTH-MULTIPLEX RECORDING

VHS HiFi is based upon a recording process that JVC calls Depth Multiplex

Recording. It uses a pair of independent rotary FM-audio heads mounted on the head drum containing the video tape heads (two or four, depending upon the VCR). Thus, for a VCR having four video heads, the total number of heads around the perimeter of the rotating drum would be six, as illustrated in FIGURE 1. As for the Depth Multiplex

principle, first the two-channel audio signal is recorded deeply into the tape's magnetic coating in the form of frequency-modulated signals. The carrier frequencies for these audio channels are 1.3 MHz and 1.7 MHz. Then the video signal, consisting of the luminance signal and the down-converted chrominance signal, is recorded on top of the audio signal in a shallower layer, as illustrated in FIGURE 2. The video signal spectrum is identical to that of the regular VHS recording system, with the FM luminance (brightness) signal having a deviation or FM spread of from 3.4 to 4.4 MHz, and the chrominance (color) signal modulated on a carrier having its center frequency at 629 kHz.

During playback, the FM audio signals in the deep layer of the magnetic tape medium are read through the video information recorded on the surface layer. Frequency distribution for the chrominance and luminance signals in a conventional VHS recorder is illustrated in the upper diagram of FIGURE 3. In the lower diagram, the frequency allocation for the extra two audio signals is depicted separately, and it is clear that the video output signal frequency spectrum remains exactly as it was in a conventional VHS VCR. As a result, video recordings remain perfectly compatible between VHS HiFi and conventional VHS machines. Furthermore, as you can see from FIGURE 1, a fixed audio head is retained in the new VHS HiFi set-up so that older tapes can be played on the yet-to-be produced VHS HiFi machines. Conversely, recordings made on a future VHS HiFi VCR would include an audio track recorded by means of this extra stationary head so that audio (either mono or stereophonic if a split, stationary head were used) would be available if the tape is played on an older, conventional VHS machine.

The presence of the third, stationary audio head lends itself to other applications. For example, in future tapes of foreign language motion pictures, the pair of VHS HiFi heads on the spinning drum might be used to record the motion picture sound tracks in stereo, while the "low fi" stationary head could be used to dub a mono or stereo audio track in the local language of the country in which the tape is distributed.

In VHS HiFi, the video heads have azimuth angles of tilt of +6 degrees and -6 degrees, while the angles of tilt for the extra pair of audio heads are +30 degrees and -30 degrees. Because of this difference, crosstalk between audio and video signals and that between audio signals on adjacent tracks are effectively suppressed.

The technical specifications for VHS HiFi read very much like those previously announced for Beta HiFi. Specifically, frequency response is flat from

IN STOCK!

Saki heads are the finest in the industry. Every head is dynamically tested and unconditionally

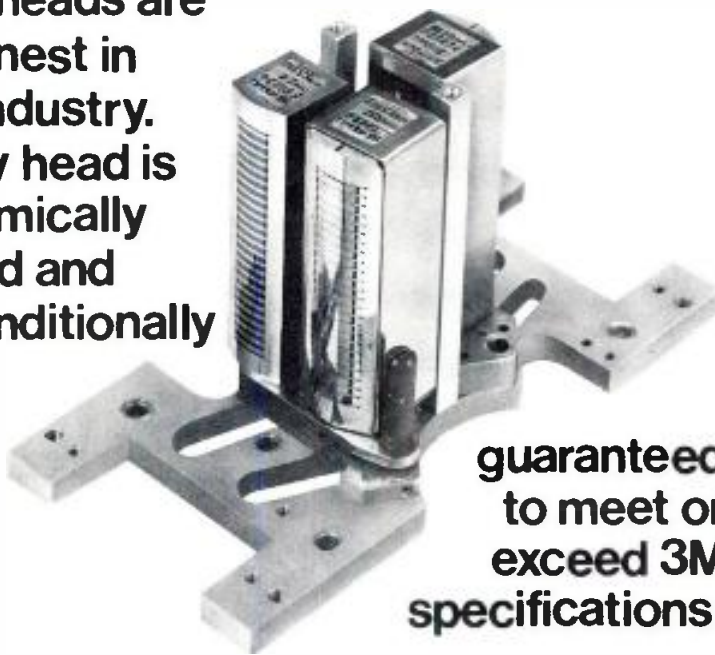

guaranteed to meet or exceed 3M specifications.



SAKI MAGNETICS, INC.

A CALIFORNIA CORPORATION

8650 Hayden Place, Culver City, CA 90230 213 / 559-6704 (TWX-910-328-6100)

See us at AES Booth 105

Circle 27 on Reader Service Card

Protect your investment with a cannon.

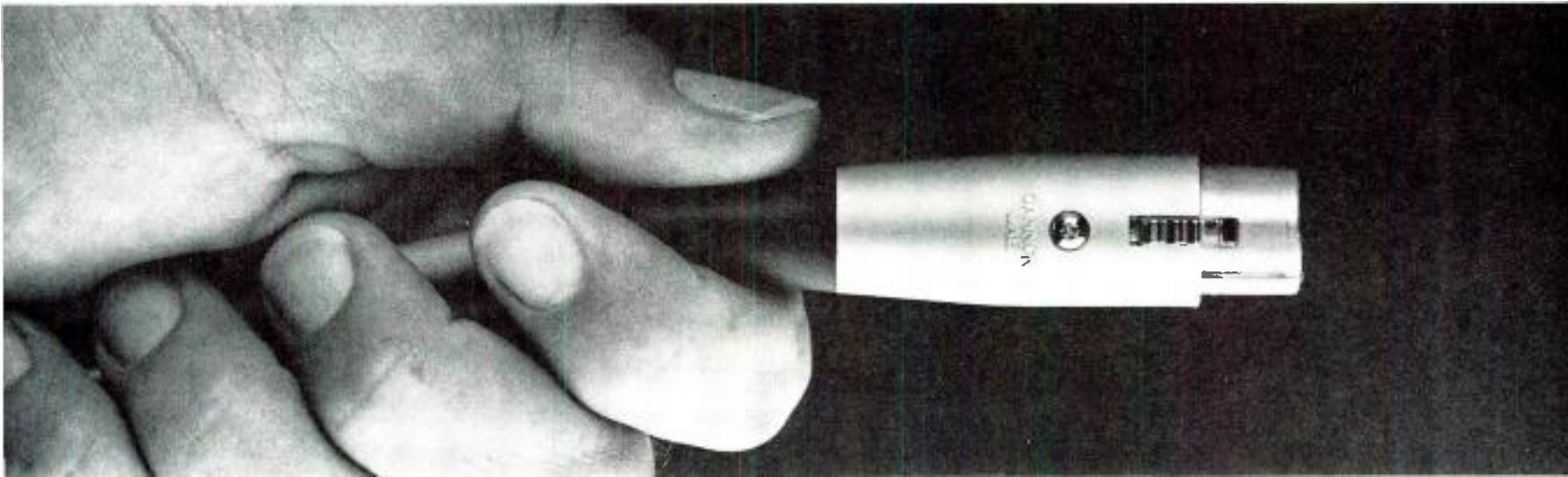

An audio connector by any other name is simply not an ITT Cannon audio connector. Which is precisely why so many audio engineers continue to specify Cannon[®] connectors for use with their audio equipment.

The XLR, the new XLB and XLA series are small, rugged, quick-disconnect connectors designed for use in audio/video and other low level circuit applications where reliability, quiet operation, elimination of mechanical interference and ease of use are necessary. Four different plug styles are available.

The EP connector is ideally suited to applications where extreme ruggedness and versatility are required. The new AP connector is a

Audio Connectors from Cannon



popular choice for heavy duty audio applications and is interchangeable and intermateable with the EP series. Both the EP and AP series may be used where as few as 3, or as many as 18, contacts are required.

The AP LNE and AX LNE are specifically designed to handle the special needs of mains and other power supply applications.

For more information, please contact International Products Marketing Manager, ITT Cannon, a division of International Telephone and Telegraph Corporation, 10550 Talbert Avenue, Fountain Valley, CA 92708, (714) 964-7400.

CANNON ITT
The Global Connection

Circle 28 on Reader Service Card

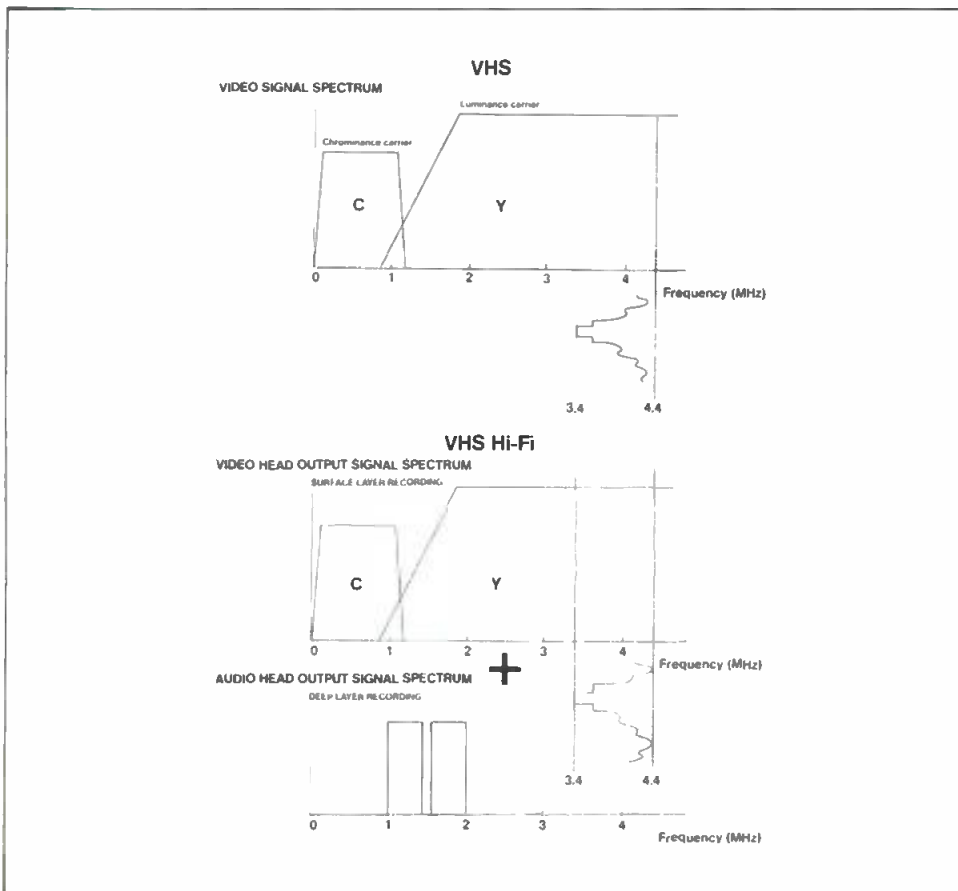

Figure 3. Video signal spectrum in VHS HiFi remains unaltered. Audio head output signals in the form of two FM carriers are added to standard VHS video signal spectrum as shown in the lower diagram.

20 Hz to 20,000 Hz; dynamic range is better than 80 dB; harmonic distortion is less than 0.3 percent; wow-and-flutter is a negligible 0.005 percent or less, and channel separation is greater than 60 dB. Frequency modulation improves the dynamic range of the audio signals to achieve more than 60 dB of dynamic range. To further expand this range to the claimed 80 dB, VHS HiFi utilizes a noise reduction system which, in their words, "is the most suitable for FM recording and playback." Specific details concerning this extra noise reduction system were not disclosed.

AVAILABILITY

The demonstration of VHS HiFi that we heard in Chicago was so effective that we wondered why JVC was not ready to quote a delivery date or even a price for the first models of VCRs incorporating this superior stereo audio system. After repeated questioning we learned that there were still some aspects of the new system that required standardization among the major producers of VHS VCRs. Upon further questioning, we learned that the VHS HiFi type machine demonstrated by Matsushita Electric (Panasonic brand) in Japan some months ago, while basically compatible with the machine demonstrated by JVC, was not totally compatible in every single detail.

While we could not determine just what areas of incompatibility remained, we were assured that whatever the differences, they were minor and would soon be resolved. If the delay leads to total compatibility (rather than a split among the producers of VHS machines), that will certainly be worthwhile. What we don't need, either from the point of view of software or hardware, are *three* incompatible systems.

PROFESSIONAL APPLICATIONS

Many industry pundits have predicted that when consumer video recorders adopt the recently agreed to 8 millimeter tape format which was described in these pages a couple of months ago, professional users of video equipment may well "move down" to half-inch tape formats, finally abandoning the U-Matic 3/4-inch format whose technical capabilities have remained fairly static over the last few years. Now that VHS VCRs appear ready to upgrade the quality of their audio channels, it is clear that electronic news gathering teams and others involved in in-the-field audio/video recording will have a choice as to which system they want to use. This becomes especially important as we come closer to the introduction of high-quality stereophonic sound on TV which, by all accounts, should finally be with us sometime in 1984. ■



PERFORMANCE • QUALITY • VALUE
**RENKUS-HEINZ PROFESSIONAL
 AUDIO COMPONENTS**



EVERYTHING IN

DRIVERS



HORNS



WOOFERS

NETWORKS

**SPEAKER
 SYSTEMS**



FREE: Send for the Renkus-Heinz Catalog describing the complete professional audio equipment line, and the name of the dealer in your area.

ASK YOUR DEALER FOR A DEMO



RENKUS-HEINZ, INC. 17851 AB Sky Park Circle • Irvine CA 92714 • (714) 540-3154

Circle 29 on Reader Service Card

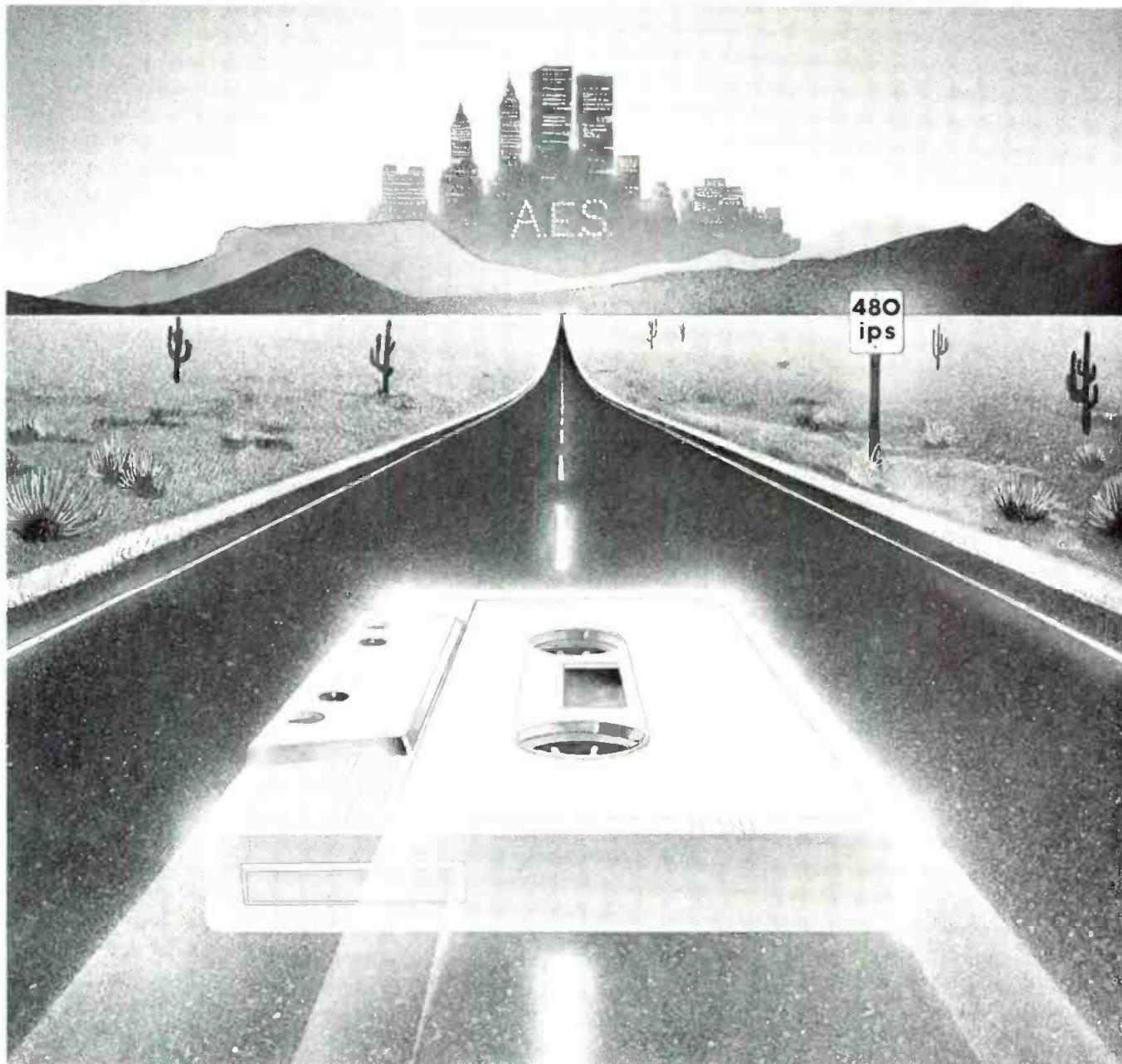

We've raised the speed limit.

Our new DP-80 high-speed duplicating system runs at an amazing 480 i.p.s. That's faster than any other duplication system. Twice as fast.

Designed especially for large production runs of music cassette tapes, the new DP-80 system means higher product quality because the masters can now be prepared at 7.5 i.p.s. That's twice as fast as any other system too.

Hear how the Otari DP-80 "Faster Masters" system can make better sounding cassettes, *and* bigger profits for you.

Make tracks—*fast*—to booth 442 at the 74th Audio Engineering Society Convention at the New York Hilton, October 9-12.

Otari Industrial Products Division, 2 Davis Drive, Belmont, CA 94002,
Telephone: (415) 592-8311, TELEX: 910-376-4890.

OTARI Technology You Can Trust

Audio Tape Duplicators & Video Tape Loaders

Circle 30 on Reader Service Card

© OTARI Corporation, 1983

20 reasons why the QSC Model 1400 should cost more. And why it doesn't.

Until now, designing a premium professional amplifier was seemingly a set procedure. All that was needed to introduce a new product was a new feature, a hot new component, more power, or perhaps some complicated circuit gimmickry designed to impress others with "technical superiority."

The results were almost always the same: very little improvement in real-world

performance or reliability accompanied by a hefty increase in price.

But we at QSC decided that you deserved more than that.

So we went back to square one, taking a hard look at professional amplifier design and construction basics. We found a lot of room for improvement. Time and technology had changed things. Approaches that had been taken for granted for years were

out of date. They needed re-evaluation... and a breath of fresh air.

With that in mind, we designed Series One. A line of amps that include a host of features (including many advancements gained from our revolutionary Series Three amplifiers) and the finest in high quality/high performance components. We examined existing construction and assembly methods and re-engineered them to be much more efficient.

The result is almost unbelievable. Take the Model 1400 for example. It's equal to or better than any premium power amp on the market in terms of features, performance, reliability, or quality of components. In terms of price,

it could command a comparable price tag. But the same rethinking that made the Model 1400 technologically superior also made it less expensive. How much less? Like we said, it's almost unbelievable: only \$698.00*.

In all modesty, we feel that we've created a whole new price-class of premium power amplifiers. A look at the features we've outlined here will give you some indication of the technology that makes the QSC Model 1400 uniquely superior. Ironically, many are the same features that make it so affordable.

To find out more about the 1400, see your QSC Audio Products dealer. After all, can you afford not to?

*Manufacturer's suggested retail price.

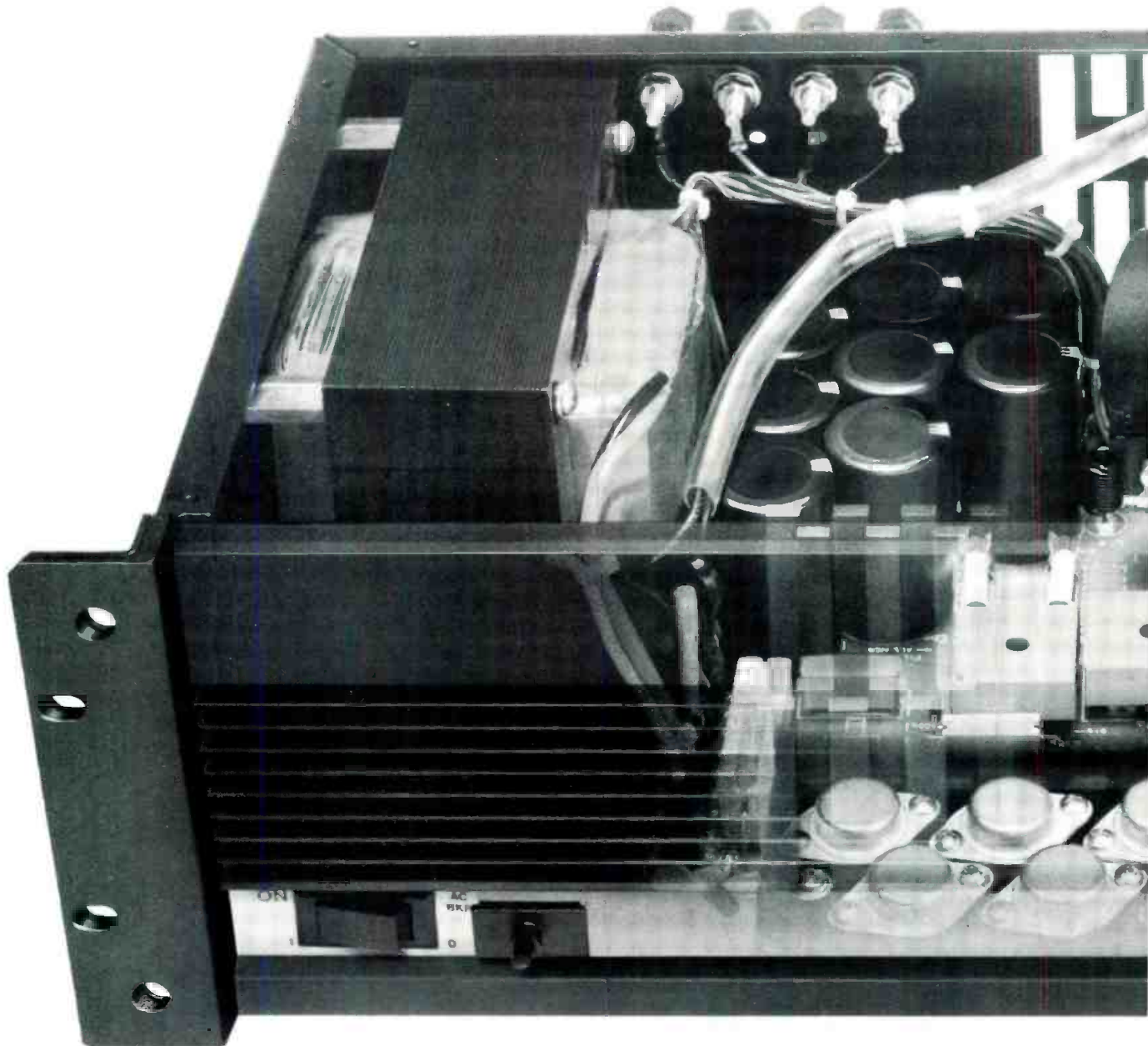

Power

A hefty 200 watts per channel @ 8 ohms, 300 watts per channel @ 4 ohms, 20-20kHz, both channels driven.

Lightweight, Compact Size

Advanced design reduces weight to a mere 27 lbs.

Flow-Through Cooling

High-turbulence heatsink thermally coupled to faceplate dramatically reduces weight. Two-speed fan with back-to-front airflow also helps keep rack cool.

Case-Grounded Output Transistors

Provide a 25% improvement in thermal transfer increasing reliability through reduction of thermal cycling fatigue and insulation breakdown.

EMI/EMC COMPONENTS

Large SOA, High Speed, Mesa Output Transistors

Renowned for their ruggedness and audiophile sound.

6. 5532 Op-Amp Front End

High speed, low-noise, and low-distortion op-amp designed explicitly for high-performance audio.

7. High-Density, Low ESR Filter Capacitors

The very latest in advanced foil technology, reduces size and weight while improving performance.

8. FR-4 Fiberglass PCB's

High quality circuit boards.

9. Single Piece 14-Gauge Steel Chassis with Integral Rack Mounts

Thicker than normal for extra strength, no welds to crack or screws to loosen.

10. Full Complementary Output Circuit

For optimum performance and power.

11. Independent DC and Sub-Audio Speaker Protection

Circuit design inherently protects speaker from DC or sub-audio

surges due to output failure. Acts independently on each channel.

12. Dual Power Supplies

Split power transformer with separate rectifiers and filters. Provides better channel separation and improved reliability.

13. Patented Output Averaging™ Short-Circuit Protection

Provides superior short circuit protection without the audio degradation found in VI limiting.

14. Thumpless Turn-On, Turn-Off

Input muting relay provides turn-on delay and instant turn-off to protect sensitive drivers and speakers.

15. Active Balanced Inputs

For superior audio performance while reducing cable-induced hum.

COMPREHENSIVE INTERFACE PANEL

16. Octal Input Socket

Accepts active and passive input modules such as comp/limiters, crossovers, and transformers.

17. ¼" RTS, XLR, and Barrier Inputs

No need for adapters.

18. Mono-Bridging and Input Programming Switches

Maximum flexibility without jumpers or patch cords.

19. Optional 70-Volt Output Transformers

Mount right on the back for use in distributed systems.

20. 2 Years Parts and Labor Warranty

A quality product backed by an extended warranty.

QSC Audio Products
1926 Placentia Avenue
Costa Mesa, CA 92627

QSC
AUDIO

CANADA: SF MARKETING, INC., 312 Benjamin Hudson, Montreal, Quebec, Canada H4N1J4

INTERNATIONAL: E AND E INSTRUMENTS INTERNATIONAL, INC., 23011 Mouton Parkway Building F7, Laguna Hills, CA 92653

Write for details and specifications on these and other products

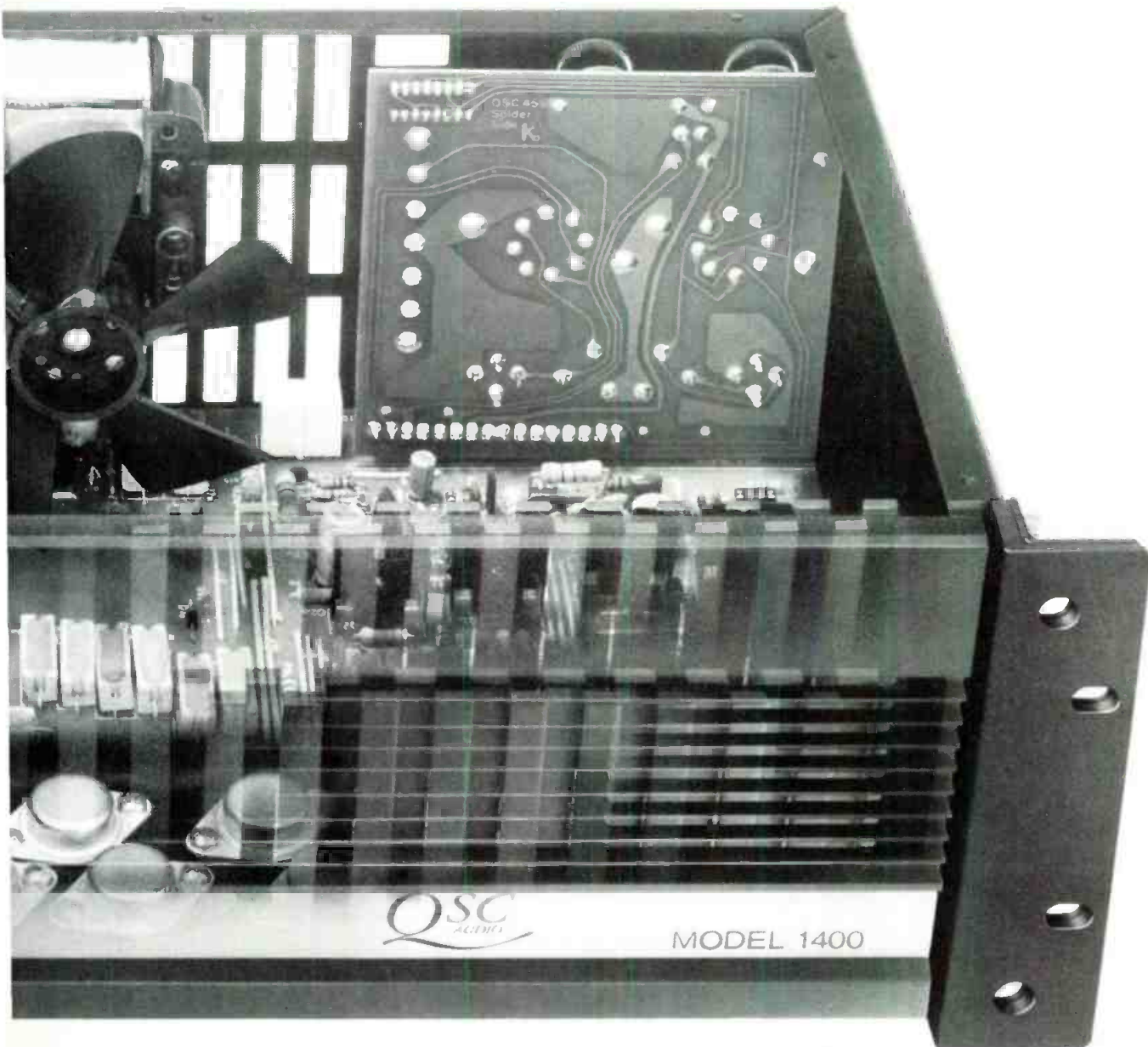

Circle 31 on Reader Service Card

Digital Audio

Re-sampling the Re-sampling Idea

• Last month we introduced the idea of building a digital re-sampling system to allow us to convert digital audio from one sampling frequency to another. This is important because, for the near future, there will be two or more "standard" sampling frequencies. It is also important for other kinds of signal processing that we will discuss later.

When we developed the idea in the previous article, we presented the

notion of creating, or recreating, the audio signal in between two discrete samples. These created audio samples were to be the new samples when sampled with a new sampling frequency. The notion of using an interpolator for this process is accurate but it prevents us from considering the problem from the more classical viewpoint. In this article, we will redevelop the concept from the classical filtering view.

We again start the discussion with an audio signal that has been sampled. This is shown in FIGURE 1. These samples are the only information extracted from the incoming signal. Because we assume the bandlimiting restriction of the Nyquist frequency, we know that the original signal could be recovered exactly by a simple operation of low-passing. In the first step of changing the sampling rate, we take these samples and place intermediate

Looking for a Distortion Analyser?

Check the little guy on the right...



1700B

339A

3501

... the highest performance, most featured and easiest to use audio distortion and noise measurement system in the industry. (and at the lowest price)

Amber Electro Design Ltd.
4810 Jean Talon West
Montreal Canada H4P 2N5
Telephone (514) 735 4105

amber

	Sound Technology 1700B	Hewlett Packard 339A	Amber 3501
Automatic Set Level	YES	YES	YES
Automatic Null	YES	YES	YES
IMD: SMPTE DIN CCIF/IHF Frequency Range	YES* NO 7kHz fixed	NO NO —	YES* YES* 2kHz-100kHz
Quantity of Filters	2	3	4
Filters user changeable	NO	NO	YES
Differential Input	YES	NO	Option
Continuous frequency tuning	NO	NO	YES
Calibrated output attenuator	NO	YES	YES
Input Monitor	YES	NO	YES
Selective voltmeter mode	NO	NO	YES
True rms meter	NO	YES	YES
Battery operation	NO	NO	Option
Options field installable	NO	NO	YES
Residual distortion 1kHz 100kHz	<0.002% <0.1%	<0.0018% <0.032%	<0.0008% <0.006%
Residual noise (80kHz BW)	<8µV	<8µV	<2µV
Maximum output	3V	6V	12V
Minimum input THD mode	100mV	30mV	30mV
Auto-null time	<6 secs	not spec	<2 secs
Voltmeter sensitivity (F.S.) extended mode	3mV/-50dBm 30µV/-90dBm	1mV/-60dBm NONE	1mV/-60dBm 1µV/-120dBm
Size (cubic feet)	1.0	1.0	0.4
Weight (pounds)	16	18	12.5
Price with IMD (*option)	\$2650 \$3625	\$2450 —	\$2100 \$2800

Circle 32 on Reader Service Card

**KEEP
YOUR RECORDING
STUDIO
COMPETITIVE
IN AN INDUSTRY
WITH
MORE THAN
33 REVOLUTIONS
PER MINUTE.**

Find out how, thanks to Sony/MCI, at the Audio Engineering Show, Booths 225, 226, 733-740, and Suite 529.



A division of Sony Corporation of America.

SONY
Professional Audio Products.

Sony Communications Products Company, Sony Drive, Park Ridge, New Jersey 07656. ©1983 Sony Corp. of America. Sony is a registered trademark of the Sony Corp.

Circle 33 on Reader Service Card

samples in between the actual samples. The extra set of samples are all with a value of 0. FIGURE 2 shows the digital samples where the odd sample numbers are taken from the real data of FIGURE 1 and the even samples are "artificial," with a value of 0. By this simple operation, we have increased the sampling frequency by a factor of 2. There are twice as many samples in the new signal of FIGURE 2 as there were in FIGURE 1.

You might object to this silly way of increasing the sampling frequency because these new zero samples do not really exist. The act of adding them here is just a conceptual way of understanding the first step in the process of determining the true value of new

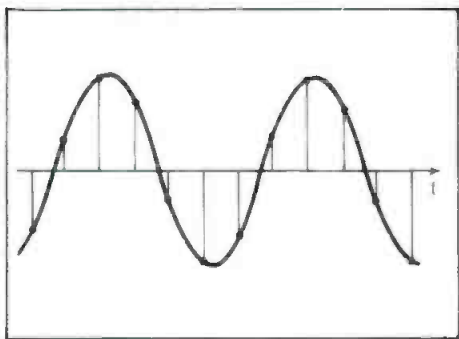

Figure 1. Incoming audio sine wave with samples at the initial sampling frequency of 50 kHz.

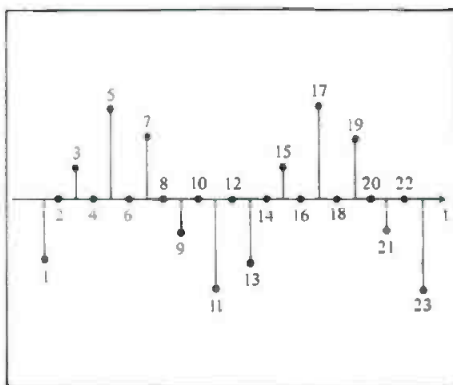

Figure 2. Digital samples at a 100 kHz rate based on the samples of Figure 1 as odd values and 0 valued samples as even. This doubles the sampling rate by rejecting artificial 0s between real audio samples.

samples. In the first step we are just creating a "placeholder" for the new samples. In the time domain, there is no new information. If we examine the signal of FIGURE 2 in terms of its spectrum, it will be the same as the original.

When we talk about the spectrum of a digital signal, we need to be very careful. With a sampling frequency of 50 kHz, we can say that the digital signal has a spectrum from 0 to 25 kHz. Frequencies above 25 kHz cannot exist. If this digital signal were to be fed to a D/A converter, then we would say that the spectrum of 0 to 25 kHz also ap-

pears as an image around 50 kHz. This is shown in FIGURE 3. Thus, the issue of spectrum is determined by the rate at which samples appear. We elect to say that a 50 kHz signal cannot exist in a sampling system running at 50 kHz; and we elect to say that the energy at DC also appears to 50 kHz, as illustrated in FIGURE 3.

What happens when we double the sampling frequency to 100 kHz by injecting artificial 0s into the sampling stream? We can now have a digital signal with 50 kHz energy. A digital sequence of alternating 0 and 1 at a

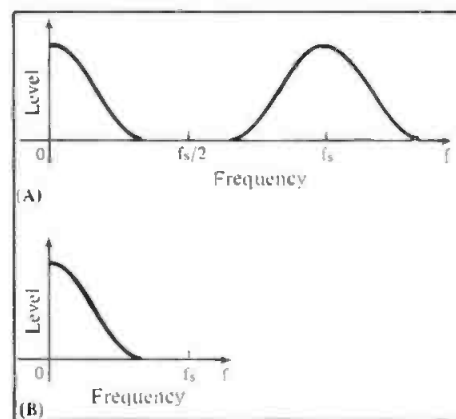

Figure 3. Spectrum of sampled audio signal of Figure 1 (lower sampling rate) as represented at the D/A (top curve—A) and as represented in the digital domain (bottom curve—B).

In times like these
it's good to know

**The first
duplicator
Garner sold
is still at
work...20
years later.**

garner industries

4200 N. 48th Street Lincoln, NE 68504
Phone: (402) 464-5911 Telex: 438068

And It Looks Like It's Going to Work Another 20

Twenty years ago, Garner Industries manufactured their first high-speed professional dubbing machine. Twenty years later, that machine is still at work, making hundreds of dubs a day. In times like these when every dollar counts, it's nice to know that Garner is still building duplicators to last, and we've made some improvements along the way. The Garner 3056 and Garner 4056 cost much less, take up less space, use less power and require far less maintenance than other duplicating machines on the market today. And the new Garner duplicators offer advantages that our first duplicator didn't have:

- Fast 60 ips speed
- No wow/flutter added because of a common capstan drive
- Simplified tape loading
- Long-life modular electronics
- Solid-state modular electronics
- Smooth, quiet operation
- Three-year mechanical warranty.

When you consider the cost of a duplicator, consider what you'll be getting for your dollar. If you want all of the state-of-the-art features in a product that's practically indestructible, then Garner has your machine. The only problem is, if you buy one of our duplicators, you may never need another duplicator.

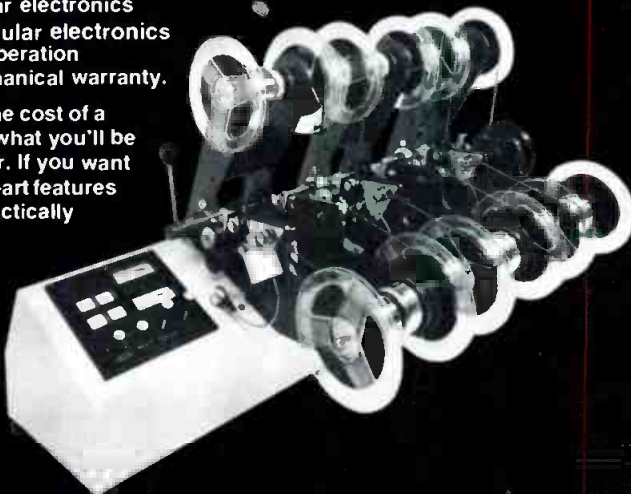

Dependability... Guaranteed

Circle 34 on Reader Service Card

EVM™ Pro-Line Speakers

As a working musician or sound-pro, you constantly work to improve and refine your performance. And we at EV know that today's performance demands a wider dynamic range and clean, clear sound. It requires higher instrument or monitor levels on stage and more punch out front. But raising your performance standards has been expensive, until now.

That's why we designed the EVM PRO-LINE Series of extra heavy-duty sound reinforcement loudspeakers. The 15" and 18" models can handle 400 continuous watts of "real world" power (not just laboratory sine waves) and an incredible 1600 watts of peak music power. The 12" models will take 300 watts continuous and 1200 watts peak under the same grueling power tests.

They're the newest genera-

tion of maximum efficiency, low-frequency speakers designed for cost effective, high-level performance. The EVM PRO-LINE can give you the extra punch you need with freedom from fear of failure—even when pushed to their limits.

All of this power handling capacity comes with the same EVM efficiency and reliability as our industry standard EVM Series II music speakers.

Couple that with EVM's 5-year loud-speaker guarantee, and our fast, efficient repair service, and you won't find a better high-powered value than the EVM PRO-LINE Series.

RAISE YOUR STANDARDS.

So raise your sound standards. See your EVM dealer or write for more information to: Greg Hockman, Director of Marketing, Music Products, Electro-Voice, Inc., 600 Cecil Street, Buchanan, MI 49107.

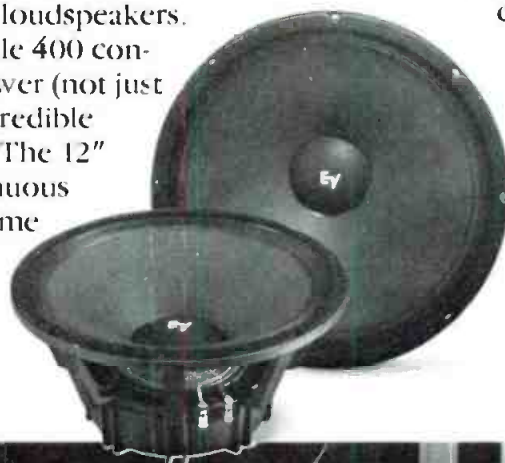

EV **Electro-Voice**
SOUND IN ACTION™

a **gulton** company

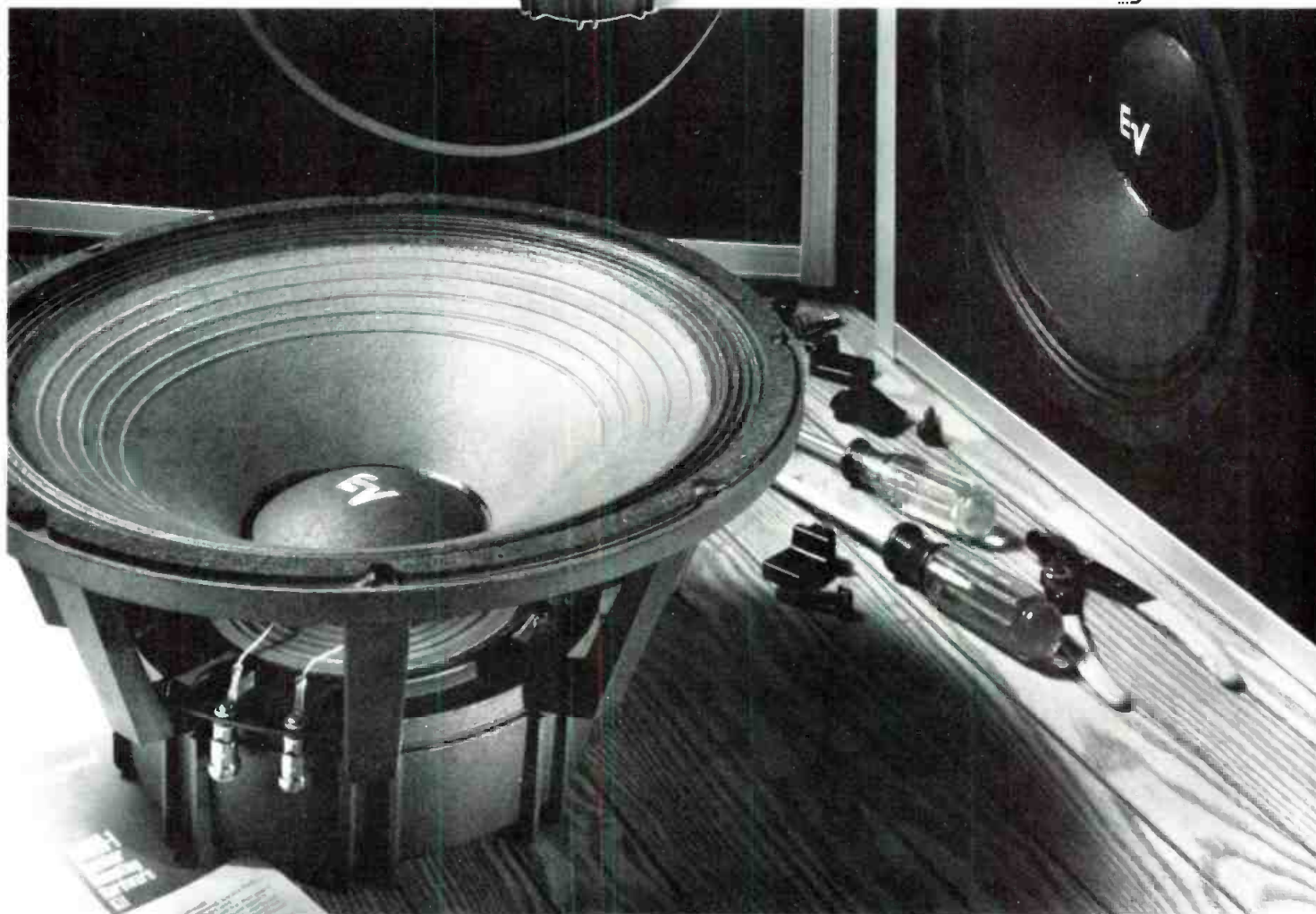

Circle 35 on Reader Service Card

Updated Recording Studio Handbook

A must for every working professional... student... audio enthusiast

Features latest state-of-the art technology of creative sound recording.

21 Fact-Filled Chapters

- | | |
|--|---|
| <p>I. The Basics</p> <ol style="list-style-type: none"> 1. The Decibel 2. Sound <p>II. Transducers: Microphones and Loudspeakers</p> <ol style="list-style-type: none"> 3. Microphone Design 4. Microphone Technique 5. Loudspeakers <p>III. Signal Processing Devices</p> <ol style="list-style-type: none"> 6. Echo and Reverberation 7. Equalizers 8. Compressors, Limiters and Expanders 9. Flanging and Phasing <p>IV. Magnetic Recording</p> <ol style="list-style-type: none"> 10. Tape and Tape Recorder Fundamentals 11. Magnetic Recording Tape 12. The Tape Recorder <p>V. Noise and Noise Reduction</p> <ol style="list-style-type: none"> 13. Tape Recorder Alignment 14. Noise and Noise Reduction Principles | <ol style="list-style-type: none"> 15. Studio Noise Reduction Systems <p>VI. Recording Consoles</p> <ol style="list-style-type: none"> 16. The Modern Recording Studio Console <p>VII. Recording Techniques</p> <ol style="list-style-type: none"> 17. The Recording Session 18. The Mixdown Session <p>Three all-new Chapters</p> <ol style="list-style-type: none"> 19. The In-Line Recording Studio Console
(The I/O Module, The Basic In-line Recording Console, Signal flow details.) 20. An Introduction to Digital Audio
(Digital Design Basics, Digital Recording and Playback, Error Detection and Correction, Editing Digital Tapes) 21. Time Code Implementation
(The SMPTE Time Code, Time-Code Structure, Time-Code Hardware.) |
|--|---|



\$39.50

The *Recording Studio Handbook* is an indispensable guide with something in it for everybody. It covers the basics beautifully. It provides in-depth insight into common situations and problems encountered by the professional engineer. It offers clear, practical explanations on a proliferation of new devices. **And now it has been expanded with three all-new chapters... chapters on the in-line recording studio console, digital audio and time code implementation.**

Sixth printing of industry's "first" complete handbook

The *Recording Studio Handbook* has been so widely read that we've had to go into a sixth printing to keep up with demand (over 30,000 copies now in print) Because it contains a wealth of data on every major facet of recording technology, it is invaluable for anyone interested in the current state of the recording art. (It has been selected as a textbook by several universities for their audio training program.)

Highly Acclaimed

Naturally, we love our book. But don't take our word for it. Here's what others have to say:

"John Woram has filled a gaping hole in the audio literature. This is a very fine book... I recommend it highly." *High Fidelity*

"A very useful guide for anyone seriously concerned with the magnetic recording of sound." *Journal of the Audio Engineering Society*

15-Day Money-Back Guarantee

When you order *The Recording Studio Handbook* there's absolutely no risk involved. Check it out for 15 days. If you decide it doesn't measure up to your expectations, simply send it back and we'll gladly refund your money.

Easy to Order

You can enclose a check with your order or charge it to Master Charge or BankAmericard Visa. Use the coupon below to order your copies of the new updated *Recording Studio Handbook* (\$39.50).

ELAR PUBLISHING COMPANY, INC.

1120 Old Country Road, Plainview, N.Y. 11803

Yes! Please send _____ copies of THE RECORDING STUDIO HANDBOOK. \$39.50. On 15-day approval.

Name _____

Address _____

City/State/Zip _____

Total payment enclosed \$ _____
(In N.Y.S. add appropriate sales tax)

Please charge my Master Charge
 BankAmericard/Visa

Account # _____ Exp. date _____

Signature _____
(changes not valid unless signed)

Outside U.S.A. add \$2.00 for postage.

Checks must be in U.S. funds drawn on a U.S. bank.

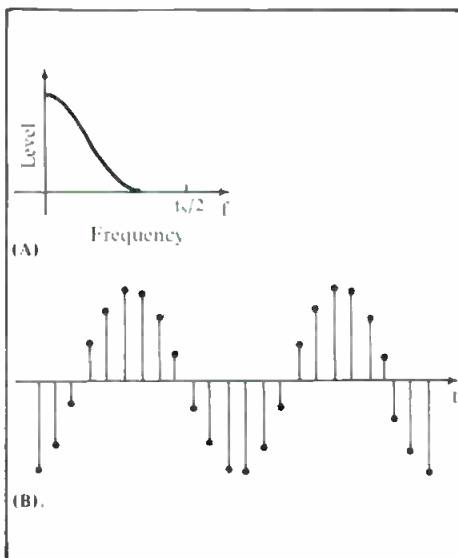

Figure 4. Spectrum of sampled audio signal of Figure 2 (higher sampling rate) as represented at the D/A (top curve—A) and as represented in the digital domain (bottom curve—B)

100 kHz rate will look like a 50 kHz square wave. In other words, doubling the sampling frequency allows the digital signal to have a representation of frequencies between 25 and 50 kHz. Doubling the sampling frequency allows the image frequencies which appear at the D/A to be represented digitally.

At the original sampling frequency of 50 kHz, the digital spectrum as shown in FIGURE 3B is limited to 25 kHz, although the analog equivalent spectrum in FIGURE 3A has the image spectrum repeated in the region from 25 to 50 kHz. When we double the sampling frequency, as shown in FIGURE 4A, the frequency axis is re-labelled with the new sampling frequency, but the spectrum at the D/A remains the same. Now, however, the digital spectrum of FIGURE 4B can represent the alias energy.

To put it simply, the doubling of the spectrum allows us to represent the

extra frequencies in the digital domain. At 50 kHz sampling, we could not represent the 50 kHz image of DC, but at 100 kHz sampling we can.

FILTERING

It would appear that we have spent a great deal of time in this discussion in order to demonstrate that we can represent the aliased spectrum in the digital domain. But why have we bothered, since this spectrum is just the "junk spectrum" of the real audio, shifted up to the sampling frequency? It is as if we had created an AM double-sideband version of the original audio.

The reason is very simple: in order to filter out this unwanted spectrum using digital filters, the junk must exist in the digital domain! FIGURE 4B is the spectrum of FIGURE 2. The unwanted junk could be removed by a digital low-pass filter that cuts off at 25 kHz. There are many ways of creating such a filter but at this point in the discussion just assume that the filter removes all information between 25 and 50 kHz. Notice that 50 kHz is the new Nyquist rate in the 100 kHz sampling system. When we do this, we are left with the spectrum shown in FIGURE 5A. This spectrum is the same as the original audio spectrum. Therefore, the series of time samples must be those which would have been there had the original audio been sampled at the higher 100 kHz rate. This equivalence is shown in FIGURE 5B.

The result of the low-pass filter allows us to actually create the samples that had been missing. The low-pass operation can be thought of as interpolation, as we discussed last month. In fact, if we look carefully at the low-pass filter we will discover that odd samples pass through at unity gain but even output samples are an interpolated version of the odd input samples. The even input samples have no contribution, since they were all zero. The better the low-pass function, the more

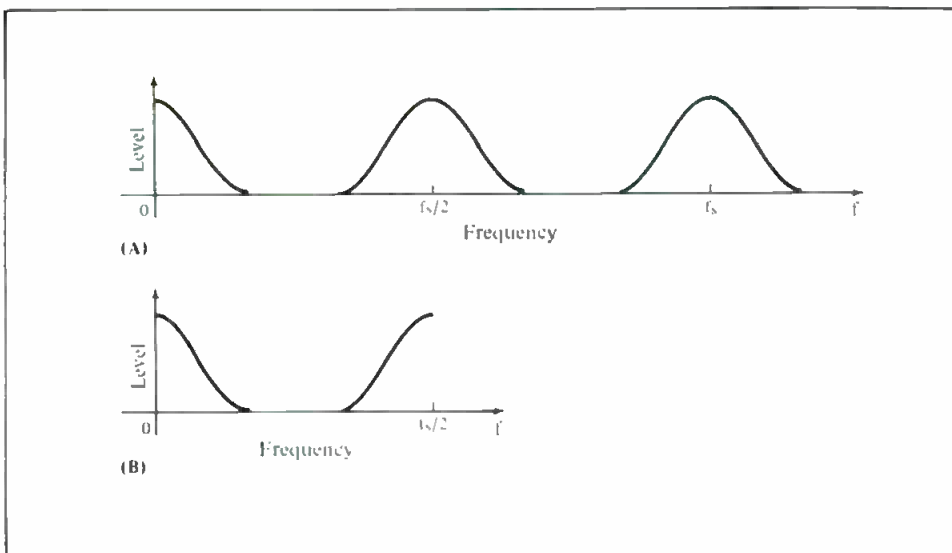

Figure 5. Spectrum of filtered (low-pass) version of Figure 4B (top) and equivalent digital time sequence (bottom).

One Stop, One Studio

Imagine...A whole studio in less time, for less money than ever before. Even our acoustics come on the truck. From the Recording Studio Equipment Company - your one stop Studio Shop. T.M. Recording Studio Equipment Co., 14205 N.E. 18th Ave., North Miami, FL 33182 Telephone (305) 945-9774

RSEC...
Exclusive
Distributors for
Modular
Perfection
Acoustical Environments

Circle 36 on Reader Service Card

Audio Tape for professionals



REEL TO REEL TAPE

Ampex, 3M. All grades.
On reels or hubs.

CASSETTES, C-10—C-90

With Agfa, TDK tape.

LEADER & SPLICING TAPE

EMPTY REELS & BOXES

All widths, sizes.

**Competitive!
Shipped from Stock!**

Ask for our recording supplies catalog.

Polyline
Corp. 312/298-5300
1233 Rand Rd. • Des Plaines, IL 60016

15

Circle 37 on Reader Service Card

complex the interpolation will be. Hence we are really looking at the quality of the interpolation filter in terms of the stop band rejection and passband flatness. Imperfect stopband reject would allow a little energy to leak into the output. Although this does not yet play a role, we will see the effect in the next discussion.

RE-SAMPLING DIGITALLY

The 100 kHz digital audio signal can be re-sampled or left unchanged. If we do nothing, then we have achieved the doubling of the sampling rate. If we take every other sample and discard the others, then we have gone back to a 50 kHz sampling rate. However, if we take every third sample, then we have a sampled audio system running at 33.33 kHz. In this case we have converted a 50 kHz input sampling rate to a 33.33 kHz output sampling rate. This is performed by going via a common sampling rate. This is performed by going via a common sampling rate of 100 kHz. Both the input and output sampling rate must relate to the internal rate by integer numbers. In this case, the 3:2 ratio requires a 100 kHz rate.

By taking every fourth sample, we would end up with a 25 kHz sampling rate; by taking every fifth sample, we would end up with a 20 kHz rate, etc. This form of re-sampling is called down-converting, since the output rate is lower than the input rate. There is a special issue in down-converting. The low-pass filter must not only remove the image region from 25 to 50 kHz, but it also must remove some of the original signal energy below 25 kHz. The example of down-converting to 33.33 kHz means that the Nyquist frequency is now 16.66 kHz. Since the original signal had a spectrum up to 25 kHz, we must remove the region from 16.66 to 25 kHz. These frequencies, which had a good representation in the original sampling rate, no longer exist. They would alias at the lower rate. Notice that the low-pass filter is like a combination of an anti-image filter in a D/A system and an anti-alias filter in an A/D system. The composite is the filter that we implemented digitally.

With up-converting, the anti-image filter dominates since it has a lower cutoff frequency than the anti-alias filter; with down-converting, the anti-alias filter dominates. These analogies to an analog re-sampler, discussed last month, are exact. The only difference between an analog sampler and a digital re-sampler is that the analog sampler can take any part of the audio signal, whereas the digital re-sampler can only discard discrete samples. The final samples in the digital re-sampler must have existed before re-sampling.

We can continue the discussion with an example of up-converting to 150 kHz

by injecting two 0s in between each original sample of FIGURE 1. The final low-pass would still cut off at 25 kHz to remove the multiple images and it would now operate with a higher output data rate. If we take every other resulting sample, we end up with a final rate of 75 kHz. If we take every fourth sample, we end up with a rate of 37.5 kHz.

The motivation for doing the process digitally instead of analog was that we could change the sampling frequency without introducing any additional degradation. There are two prime mechanisms for degradation: quantization noise and aliasing. If you will remember the discussions on filtering, we need to have a large word size internally to prevent the equivalent of quantization noise after multiplications. Multiplying a 16-bit audio sample with a 16-bit coefficient results in a 31-bit result. This is renormalized to 16 bits by chopping off the lower 15 bits. We should be careful that this chopping only appears at the end of the process, and not at each step. Chopping off the lower bits is directly equivalent to an A/D conversion. Quantization noise is the error contained in the difference between the chopped and unchopped signals. Even in the best of cases, we can expect some noise to be added; perhaps as low as 1 dB if we are very careful.

The second class of degradation comes from the fact that the low-pass filter may not be perfect. Like the analog equivalent, we will create aliasing. In this sense, the filter should be on the order of 100 dB stop-band if we are to maintain signal purity. These two issues are essentially the only ones which determine quality of re-sampling. Since digital design does not have component issues, once the system has been designed properly, there is no further problem. There is no such thing as aging.

COMPUTATIONAL SOPHISTICATION

We should note that the higher the internal sampling rate, the more computational burdens. Sharp low-pass filters can become very long as the rate is increased. Each doubling of the rate doubles the number of multiplications in the filters. We should thus look for some computational simplifications. The first one to notice is that with the first up-conversion, the extra data is actually made up of 0s. Clearly, multiplication of a filter coefficient by 0 will not need to be done since the result is also 0. When we up-convert to 500 kHz from 50 kHz we nominally raise the data rate by a factor of 10, but 9 of every 10 input samples are actually 0.

If we do a little unscrambling of the process of filtering, we will notice that we have actually created 10 distinctly

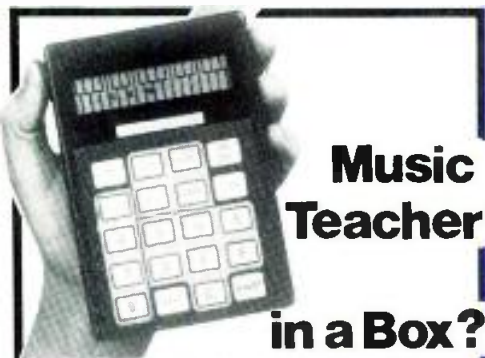

Music Teacher in a Box?

To get ahead in music, you need to know music theory. PAIA's Chord Computer helps you understand both music and keyboards better by cramming the equivalent of pages and pages of music theory into a compact, calculator-style package.

The Chord Computer is easy to use. Simply select a chord letter, and the Chord Computer's LCD 31-key piano keyboard display will show which notes to play for the selected chord. Press another button to choose sharp, flat, major, minor, augmented, diminished, 6th, 7th or 9th chords — including inversions. The Chord Computer can also display complete scales for all keys, or even transpose them at the touch of a button.

Serious about music? The Chord Computer could be the best investment you'll ever make. **only \$59.95** (plus \$2.50 postage/handling) **Order yours today...**

CHARGE TO VISA OR MC TOLL-FREE
1-800-654-8657 9AM to 5PM CST MON-FRI

Ask for your free PAIA catalog.

Direct mail orders and inquiries to: Dept. 10D

PAIA Electronics, Inc.

1020 W. Wilshire, Oklahoma City, OK 73116 (405)843-9626

Circle 39 on Reader Service Card

THE BEST-DRESSED RACKS GO BY THE BOOK.

ALTEC LANSING— the choice of sound professionals for over 50 years.

1674—4-Channel Automatic Microphone Mixer shares gain among individual mics in multi-mic set-up. Increases gain of in-use mics, lowers others for hands-off mixing.

1678—8-Channel Automatic Microphone Mixer with same features as 1674.

1689—2-Channel Mono/Stereo Mixer/Preamplifier. Includes phantom power, mic and line level inputs.

1651—Single Channel Graphic Equalizer with 10 1-octave, active filter sections. Up to ± 12 dB boost/cut with center detented slide controls.

1652—Stereo Graphic Equalizer with same features as 1651 for each channel.

1268—Stereo Power Amplifier. 60+ watts/channel into 8 ohms 20 to 20kHz at less than .03% THD. 200 watts/mono. Optional line transformers for balanced input. Computer protection of amp and load.

1269—Stereo Power Amplifier. 120+ watts/channel, 400/mono, with same performance and features as 1268.

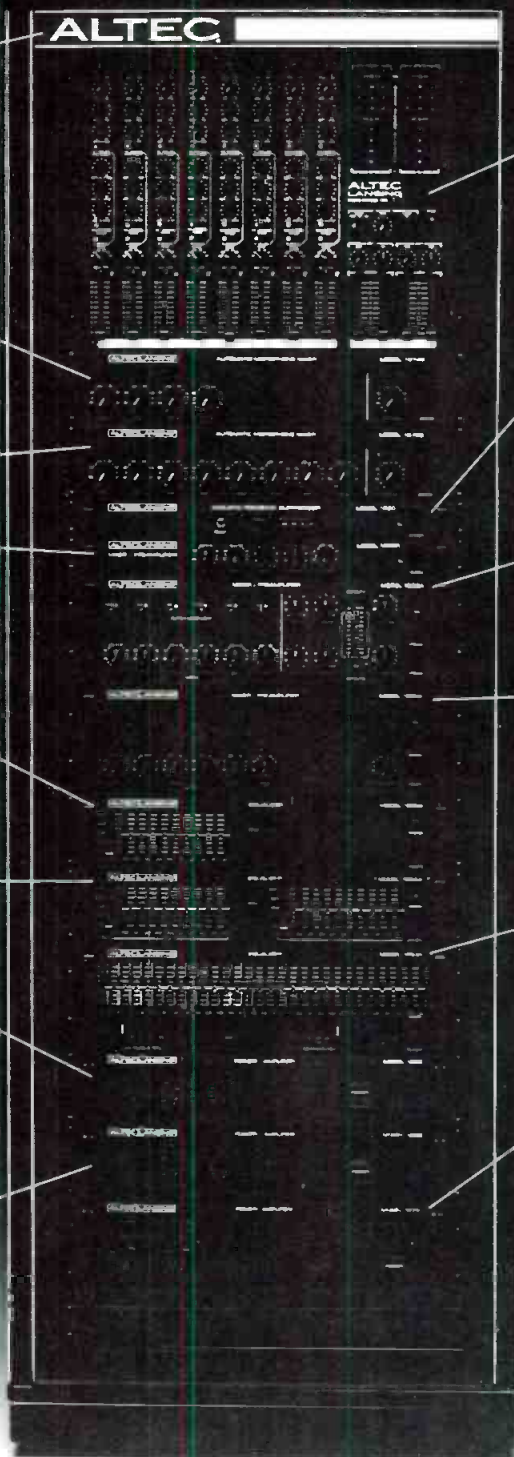

1690—8-Channel Stereo Mixer/Preamplifier for sound reinforcement, recording and mixdown. Linking connectors allow coupling additional 1690s for expanded versatility.

1620—Acoustic Feedback Suppressor automatically detects feedback oscillations, lowers gain and adjusts system to optimum level for hands-off feedback control.

1692—6 in, 2 out Mixer/Preamplifier. Each input with volume, gain, high pass, phantom power and optional remote volume control.

1699—6 in, 2 out Mixer/Preamplifier/Mixer Extender. "Link out" feature provides 12 independent channels when paired with 1692.

1653— $\frac{1}{3}$ -Octave Graphic Equalizer with 29 active filter sections, 25 to 16kHz. 18 dB/octave continuously variable high and low pass filters.

1270—Stereo Power Amplifier. 400+ watts/channel into 4 ohms, 800 into 8 ohms/mono. Computer circuits protect amp and speakers. Fan cooled. VI limiter helps the 1270 handle the toughest loads.

Altec Lansing's Black Rack Book—featuring Altec's new line of power amps, mixers, equalizers and related electronics. Precision-matched for optimum sound power and control, Altec's components work together for increased system efficiency and performance. For the ultimate in custom-tailored sound for your system, send the coupon to:

**ALTEC
LANSING**

Black Rack Book
P.O. Box 3113
Anaheim, CA 92803

Name _____

Address _____

City, State, Zip _____

Occupation _____

DB

Circle 38 on Reader Service Card

different filters, each of which operates at the original sampling rate. Using our previous notation, we have 10 different interpolation filters corresponding to 10 different delays in steps of 2 μ secs. In the up-converting, we increase the complexity of the hardware but not the data rate.

Now let us take a look at the output process. Assume that we wish to take every ninth sample to create a final result of 55.55 kHz sampling. The eight samples which we ignore do not have to be computed since they are to be discarded! In this curious way of looking at things, we observe that the internal high-frequency sampling process does not actually exist except as a conceptualization. Why compute results which are to be ignored? To take advantage of this set of facts, the re-sampling system must know its input and output sampling rate. Although the filters do not become much larger as the ratios change, the size of the coefficients for filtering does become larger. With a ratio of 120 to 121, the effective rate is 120 times the actual rate. There will thus be 120 sets of simple interpolation coefficients which need to be called up depending on the sample index.

In the next series of articles, we will explore some of the applications of the idea of re-sampling as it applies to current issues. This discussion is the most fundamental and most classical description. ■

Interest in New U.S. Savings Bonds is growing daily at Singer in Stanford.

Cathy Porricolo

"Savings Bonds are not only a good investment for my future, but also the future of my country."

Terence J. Saunders

"I buy U.S. Savings Bonds because I wish to invest in America's future."

Harry P. Hancock

"By purchasing Savings Bonds through the company's Payroll Savings Plan, I can save without ever actually seeing the money."



NEW
VARIABLE RATE BONDS

MAKE IT
SMART TO

Take
stock
in America.



Ad
Council

A Public Service of This Publication

Director of Sales
Department of the Treasury
U. S. Savings Bonds Division
Washington, D. C. 20226

Yes, please send me Free information about the Payroll Savings Plan.

Name _____

Position _____

Company _____

Address _____

City _____ State _____ Zip _____

OUR FIRST YEAR, 1958.

Gotham Audio Corporation revolutionizes the stereo disk recording industry and significantly upgrades the American studio scene by offering, in one place, the world's most sophisticated audio equipment and engineering backup.

Sound Reinforcement

Microphones in Sound Reinforcement, Part 3: Calculating and Measuring the Gain of a Sound Reinforcement System

• In last month's column we stated that, in most sound reinforcement systems, the microphone is located in the reverberant field of the loudspeaker, and in the direct field of the talker. We will now calculate the gain of the reinforcement system for a listener in the reverberant field of the loudspeaker. The gain of a sound reinforcement system is defined as the difference in level, as perceived by the listener, between the system *off* and the system *on*.

In FIGURE 1A, we show the basic

dimensions of the system, including pertinent acoustical data. Our first step is to determine the level of the talker alone, as heard by the listener. Let us assume that the talker produces average speech levels of 70 dB at a distance of one meter. Then, using the graphical data of FIGURE 1B, we observe that beyond the critical distance of the talker, D_c , the level is determined by the reverberant field of the talker. Thus, at the listener, the level is given by:

$$\text{Level} = 70 - 20 \log D_{rl} = 51 \text{ dB.}$$

Now we are ready to turn on the system. We can increase the gain until the system just begins to go into feedback. That will be when the loudspeaker produces, at the microphone, a level just equal to that of the talker, or 70 dB. Of course, we cannot operate the system at such an unstable gain setting, and it is customary to reduce the gain by 6 dB. When the reduction in gain is made, speech levels of 70 dB at the microphone will result in loudspeaker-producing levels of 64 dB at the microphone. Since the listener and

**OUR
TWENTY-FIFTH
YEAR.**

DITTO.

SEE OUR EXHIBIT AND CELEBRATE WITH US AT THE WARWICK HOTEL DURING THE NEW YORK AES CONVENTION, OCTOBER 9-12, 1983.

Circle 40 on Reader Service Card

INNOVATION

CRAFTSMANSHIP • ACCURACY

• New Continuous Frequency Distribution (fms) enclosures & baffles • Custom design & fabrication • Precision lamination • Hand laid fiberglass • Extensive balsa core • Spun woven throats • Professional & Commercial lines • 5 Year Warranty •



booth 307
A.E.S.

Design Direct Sound, Inc.

6850-35TH Ave. N.E.
Seattle, WA 98115, USA
Tel.: (206) 527-4371

Send For Complete Literature:

name _____
company _____
street _____
city _____
state _____ zip _____

Circle 41 on Reader Service Card

Q: The Department of Defense picked what sound effects library as the one to use in all their radio stations around the world?

The Production EFX Library.
5 stereo albums arranged by categories.
Shouldn't you give a listen?

A:

Stereo Sound Effects

PRODUCTION EFX LIBRARY
2325 Girard Ave. S.
Minneapolis, MN 55405

Circle 43 on Reader Service Card

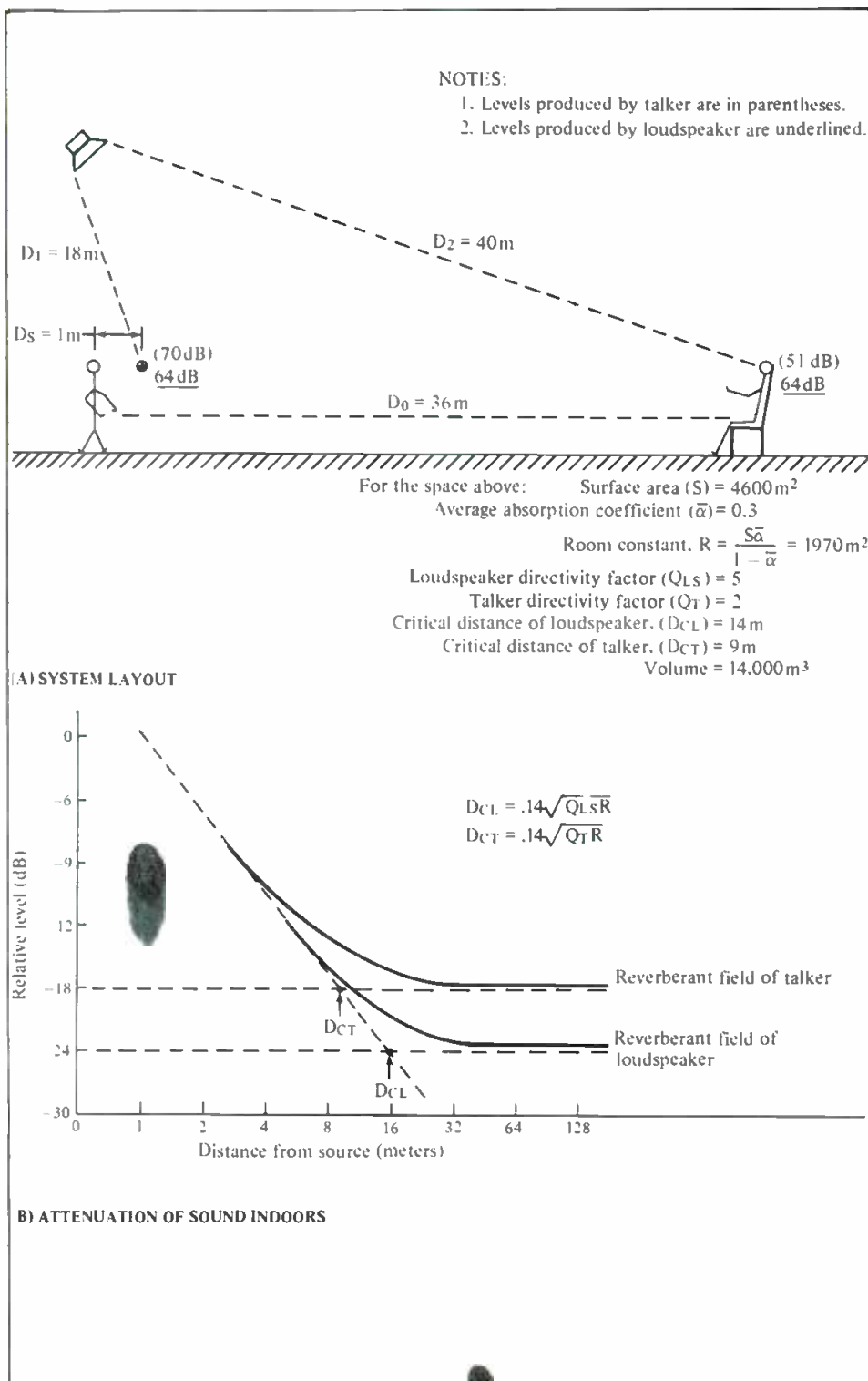

Figure 1. An indoor sound reinforcement system.

the microphone are both in the reverberant field of the loudspeaker, it follows that the level at the listener, due to the loudspeaker, will be 64 dB as well. Therefore, the gain of this system is:

$$\begin{aligned} \text{Gain} &= 64 - 70 + 20 \log D_{ct} \\ &= -6 + 20 \log D_{ct} \\ &= -6 + 19 = 13 \text{ dB.} \end{aligned}$$

This condition assumes that the talker-to-microphone distance is fixed at one meter. If we make this distance, D_s , variable, we can then increase the

gain by the following amount, $-20 \log D_s$.

For example, decreasing D_s to 0.5 meter will increase the level at the talker by 6 dB. So, we can modify our gain equalization as follows:

$$\text{Gain} = 20 \log D_{ct} - 20 \log D_s - 6.$$

So far, we have assumed that we were using an omni-directional microphone. If we use a directional microphone, we can increase the system's gain potential by the following amount, $-10 \log REE$, where REE is the random energy

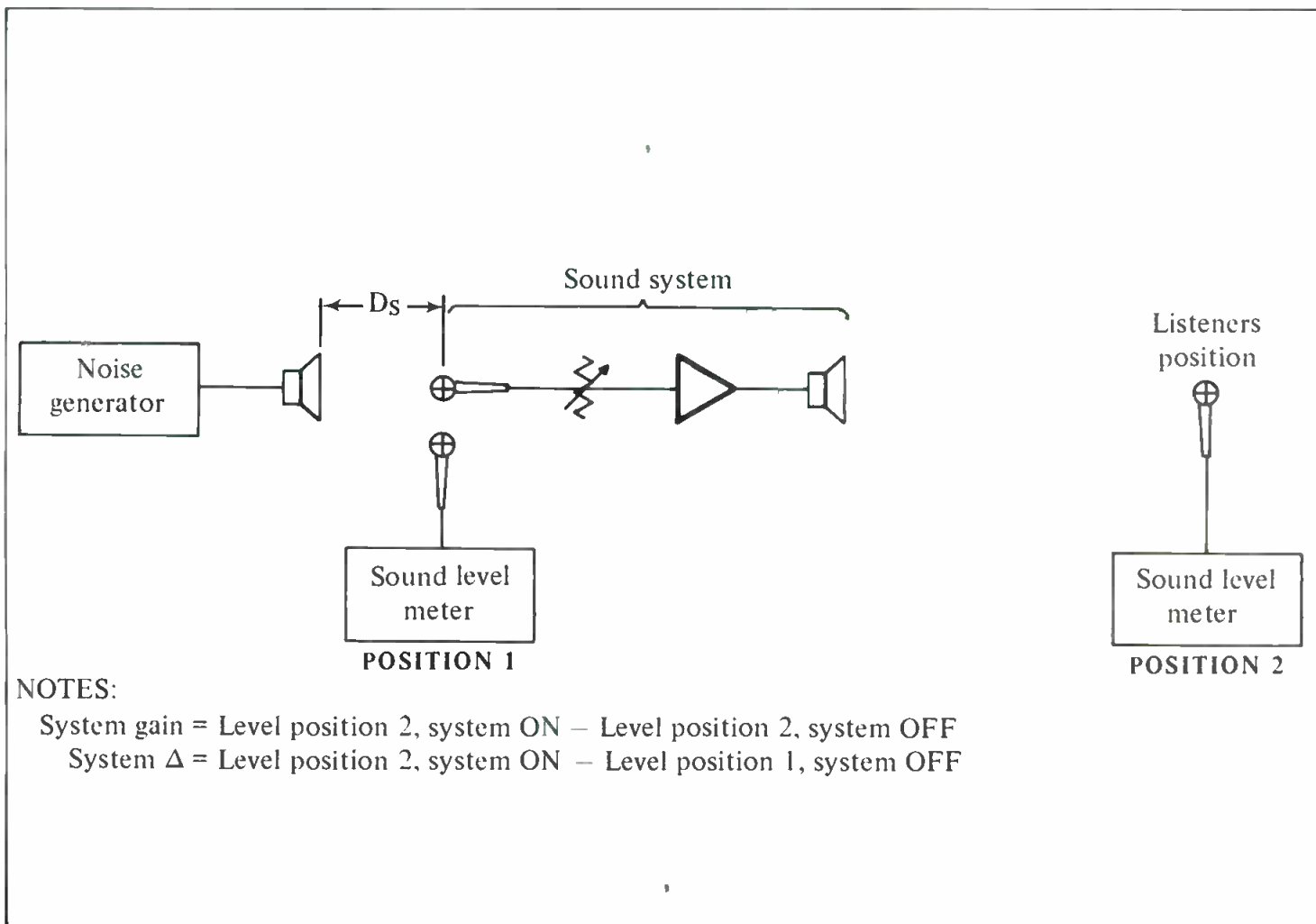

NOTES:

System gain = Level position 2, system ON – Level position 2, system OFF
 System Δ = Level position 2, system ON – Level position 1, system OFF

Figure 2. Measurement of system gain and Δ (delta).

efficiency of the microphone, as discussed in last month's column. Recall that *REE* is a measure of the microphone's ability, by virtue of its directional pattern, to reject reverberant information relative to direct, on-axis information. Thus, for a cardioid pattern with *REE* = 1/3, we will gain an additional $-10 \log 1/3$, or 4.8 dB gain potential.

We can now write the gain equation in its final form:

$$\text{Gain} = 20 \log D_{et} - 20 \log D_s - 10 \log REE - 6.$$

The equation we have developed here gives the *maximum* gain we can expect of the system. In practice, we can come within a couple of dB in realizing this value—especially if equalization is judiciously applied to reduce any tendency toward acoustical feedback.

FIGURE 2 shows a set-up for measuring acoustical gain. A small loudspeaker, typically a 4- or 5-inch unit, is placed in the normal position of the talker. The response of this loud-

speaker should be uniform over the range from 250 to 4000 Hz. With the reinforcement system turned off, the test loudspeaker is fed a pink noise signal, limited to the range from about 700 Hz to 1.5 kHz, and adjusted to produce a level at the microphone of about 80 dB(A), as measured with a precision sound level meter.

Next, the meter is located at a point well out into the auditorium, and the level there is carefully noted. The system is then turned on and the gain advanced until it is just below the point of feedback. Under this condition, the level at the distant point in the auditorium is again noted.

Acoustic gain is defined as the *difference* between these two points in the auditorium.

SYSTEM DELTA (Δ)

Paul Boner, the father of modern sound reinforcement system analysis, proposed the quantity Δ (Greek "delta")

as a measure of system gain. A Δ of zero dB represents the maximum gain a system can possibly produce. Given directional microphones and careful narrow-band equalization, it is possible to approach this value within 2 or 3 dB.

CONCLUSION

It is best to design sound reinforcement systems with as much gain margin as possible. This usually means restricting the number of open microphones (to be discussed next month), and keeping the value of I/λ as small as possible. A fixed podium microphone is of course quite desirable from the user's viewpoint, but this means that I/λ is entirely in his hands. The use of a cardioid microphone may increase the gain margin by 3 or 4 dB over an omnidirectional one, but critical gain situations will require some kind of personal microphone, such as a lavalier or tie-tack microphone. ■

Watch Out For Those Lasers!

YOU'VE PROBABLY READ the news: "Compact Discs Revolutionizing the Listening Habits of Many Metropolitan-Area Music Lovers." So says a recent news release from the Compact Disc Group, a consortium of some 30 record labels and CD manufacturers who devoutly hope CD will actually live up to their PR efforts. The release quotes David Hunt, a local record store manager, who has yet to find a CD "whose sound is less-than-phenomenal. Everyone who hears [CD] feels the same way." Dave. meet Doug. In another news release that is making the rounds, Sheffield Lab president Doug Sax says that, for him, "...all digital attempts thus far have been a failure."

Back to you, Dave. "After exposing some diehard buffs to the Compact Disc, they've offered me their entire record collections, because they don't want to listen to analog again." (Make an offer, Doug.)

Are these guys talking about the same medium? And if so, which one is right? Not trusting our own ears (all that waxy yellow build-up, you know), we called on Michael Tapes, Sound Workshop's resident technofreak, hi-fi nut, and computer maven, to have a go at it. (See his report in this issue for more details.)

After the report was done, we joined him for some additional listening. A recording of the Goldberg Variations made for an interesting comparison. If one could tune out the traditional analog surface noise, the LP was clearly the sonic winner—in fact, it was no contest. By comparison, the CD sounded filtered.

Is this an indictment of CD, or an indication that other variables need to be carefully studied before coming to any conclusions? Or is it just that in this isolated case, and on this particular system, the LP managed to better survive the playback process? For the moment, there aren't any clear answers, but there are a lot of variables to be considered.

One variable that needs some attention from all of us is the hype factor. As we recall, the last time anything sprang to earth fully developed was during the age of mythology. Subsequent miracles have usually taken a bit more time to reach perfection. For example—and contrary to what you read elsewhere—the compact disc did not leap fully mature and all-perfect from its Japanese/Dutch womb. Like all newborns, it will need to be given the chance to crawl, before expecting it to fly. (The db Metaphor Filter is out for cleaning and servicing.)

Yet the local hi-fi press, and the various PR firms, are carrying on as though the new contender has already wiped out the competition. On the other hand, practically every critical listener we've encountered has expressed at least some reservations about the current state of digital audio. This certainly does not mean that its technical validity is under suspicion. But it does suggest that all the questions have not yet been answered, and for the moment at least, analog funeral services might be premature.

This little bit of news has not yet penetrated the minds of some of the digital folks, who are doing their damndest to smother analog audio under a blanket of digital double-speak. Studio Sound Magazine reports of one company which labels its CDs with "Digital Recording," if indeed they are. If they are not, then they are labelled "Digitally Mastered." The word "Analog" (actually, Analogue) is not allowed.

Where does all this leave our beloved source of support—the consumer? Confused, no doubt. And that confusion is being helped along by those who would use the digital mystique to imply that analog recordings now released in the CD format are, miraculously, "digital." As noted, the "Digitally Mastered" proclamation is the truth—but only half of it. You know what the other half of the truth is, but does the consumer? In many cases, probably not.

To find out a little more about what it's like out there in Consumerland, SPARS coordinator Gary Helmers wandered into a few West Coast record stores, where various sales people told him everything one needs to know about digital. As one fellow put it, "I don't know what digital means, but it sells records." Another was a little more cautious: "You have to be careful with those lasers; they can hurt you."

Well, perhaps they can, if the rhetoric doesn't poison you first.

Remember quad? Although our beloved FCC was instrumental in killing it off, they certainly were helped along by the industry itself. While waiting for the FCC to get its act together, we were treated to a side-show of preposterous prose on the merits of this or that system. Needless to say, none of the systems had a fighting chance of living up to the claims. Perhaps eventually, but certainly not at birth. The public became confused, disenchanted, and eventually, disinterested.

And now, quad's out, digital's in. It's as perfect today as quad was ten years ago. Let's hope its more enthusiastic supporters don't promote it right into the ground.

Chances are, they won't be able to do so, although some of them are certainly trying hard. But digital technology seems to have enough going for it to help it survive its birth pains, and its promoters. Even its severest critics recognize the long-term potential of the emerging technology.

Now if only its supporters could acknowledge that tomorrow isn't here just yet, and then get back to the business of today, which is, helping digital audio live up to its potential.

MORE ON AES CONVENTIONS

As we reported some months ago, the AES board of governors voted at its last meeting to return to three conventions a year. Some were pleased—others weren't. Lately, some of those others have been actively campaigning against the three-show schedule.

Still others are wondering why those who don't want three shows a year can't get by simply by not attending the show(s) of their choice. This would leave everyone else free to do as they please, too.

Of course, if there's a show, and you don't go to it, and someone else does, and someone else makes a sale...

Of course, that just couldn't happen here, since the AES is not a selling show. Of course.

So there's really nothing to worry about. If the public doesn't want three AES conventions a year, it won't support three shows a year. Pretty soon, we'll be back to two a year (maybe even one), and nobody will have to do any campaigning to protect the un-enlightened from themselves. Simple, huh? (And remember, you read it here first.) JMW

Before you invest in new studio monitors, consider all the angles.

No one has to tell you how important flat frequency response is in a studio monitor. But if you judge a monitor's performance by its on-axis response curve, you're only getting part of the story.

Most conventional monitors tend to narrow their dispersion as frequency increases. So while their on-axis response may be flat, their off-axis response can roll off dramatically, literally locking you into the on-axis "sweet spot." Even worse, drastic changes in the horn's directivity contribute significantly to horn colorations.

Introducing the JBL Bi-Radial Studio Monitors.

At JBL, we've been investigating the relationship between on and off axis frequency response for several years. The result is a new generation of studio monitors that provide flat response over an exceptionally wide range of horizontal and vertical angles. The sweet spot and its traditional restrictions are essentially eliminated.

The key to this improved performance lies in the unique geometry of the monitors' Bi-Radial horn! Developed with the aid of the latest computer design and analysis techniques, the horn provides constant coverage from its crossover point of 1000 Hz to beyond 16 kHz. The Bi-Radial compound flare configuration maintains precise control of the horn's wide 100° x 100° coverage angle.

1. Patent applied for.

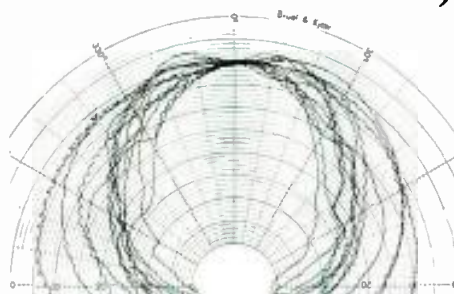

Typical horizontal

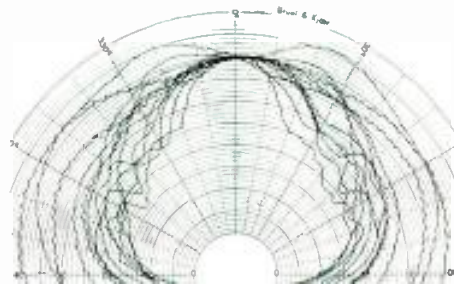

Typical vertical

Polar response comparison of a typical two-way coaxial studio monitor and JBL's new 4430 Bi-Radial studio monitor from 1 kHz to 16 kHz.

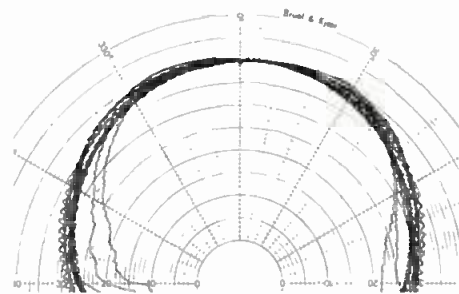

JBL 4430 horizontal

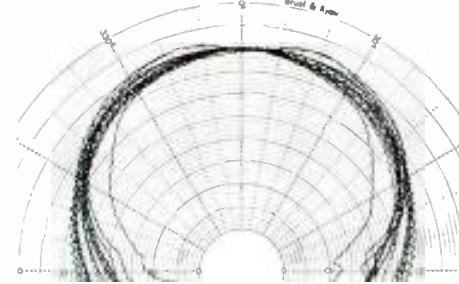

JBL 4430 vertical

And the Bi-Radial horn's performance advantages aren't limited to just beamwidth control. The horn's rapid flare rate, for instance, dramatically reduces second harmonic distortion and its shallow depth allows for optimal acoustic alignment of the drivers. This alignment lets the monitors fall well below the Blauert and Laws criteria for minimum audible time delay discrepancies.

But while the Bi-Radial horn offers outstanding performance, it's only part of the total package. The new monitors also incorporate JBL's most advanced high and low frequency transducers and dividing networks. Working together, these

components provide exceptionally smooth response, high power capacity, extended bandwidth, and extremely low distortion.

Judge For Yourself

Of course, the only way to really judge a studio monitor is to listen for yourself. So before you invest in new monitors, ask your local JBL professional products dealer for a Bi-Radial monitor demonstration. And consider all the angles.

James B. Lansing Sound, Inc.
8500 Balboa Boulevard
P.O. Box 2200
Northridge, California 91329 U.S.A.



JBL / harman international

Available in Canada through Goulet Marketing, Montreal, Quebec

Recording Studio Consoles and Film Production

Modifying a recording studio console for film production is relatively easy—until Dolby stereo requirements come into play.

THIS ARTICLE WAS JUST going to be about how to modify a recording studio console for use in film production. But before going into how, it might be a good idea to look at why. After all, even though there are certain similarities between film and record production, there are a lot of important differences, too. Probably the most fundamental difference—from the point of view of the recording engineer—is the manner in which the “final mix” is assembled.

But even before that stage is reached, the “basic tracks” are usually recorded in an entirely different way. When making a record, there is, of course, the artist(s), the engineer and the producer—all working together at the same time, in the same recording studio. When making a film sound track, a lot more variables are involved.

So, let's begin with a little basic film production technique, which may be of specific interest to recording engineers whose previous experience is entirely based on LP record production. All you pro' film folks can skip ahead if you like.

While the film is being shot, the director works with the actors and a location sound recordist. Location sound is usually done on quarter-inch tape on a Nagra, using wireless or shotgun microphones. Sync is laid down by the Nagra on the tapes, which are called “dailies.” The dailies are numbered, notated in a log, and taken to a transfer studio where they are transferred to magnetic stock.

The magnetic stock—or simply, “mag”—is a film base coated with ferric oxide—in essence, sprocketed tape. The two major categories of mag are full coat and mag stripe. Full coat is used for three-, four- and six-track recording, while mag stripe is used for mono work.

Once transferred, the mags are “synced to pix,” which means making the clapboard (that is, the sound) and the pix fit together. Pix are the prints taken from the film shot the day before. The synchronization process is one where pix and mag are put on a common-spool drive and wound through a projector/player with parallel sprockets. This is done to verify the proper synchronization of film and sound. The director and primary film editor now collaborate and do a “first assembly,” which is actually the preliminary cutting. Once this is done, black-and-white dupes are made.

A number of transfers may be made from the synced mags. These are distributed to the film editor, sound editor(s), and the music-score composer. At this point, the dialogue is refined, looped, and cut to pix. While the dialogue is worked on, the sound effects are refined and any necessary “Foleys” are recorded and cut to pix. Foleys are those sounds produced on a specially-equipped sound effects stage (a Foley Stage).

Next, the composer tries to write a score for the final cut, and record the tracks. The recorded score is then conformed to the final cut.

By this point, the sound track may be comprised of a

myriad of separate rolls of 35mm mag stock. To keep track of the overall soundtrack continuity, cue sheets are usually made up at the time.

“THE MIX” is approaching! Depending on whether this will be a mono mix or in Dolby stereo, the console will have to meet different requirements. In reality, the “mono mix” is usually a three-track mix (dialogue, music, sound effects) on a four-track recorder, with each track mixed separately. The fourth track is set aside for spare effects.

When film is being mixed, it is done using a collection of mag playback machines, each playing back one to four tracks of a given sound. These playback mags can each be considered analogous to a track on a multi-track tape recorder. Aside from editing, an advantage is that at any time in the production, any sound effect may be moved forward or back, in relative time to the track.

Each of these tracks is fed to the console, as is the music, and depending on the type of sound, sent to its corresponding bus. The recording is usually done on a four-track “pick-up” type of mag recorder, capable of inaudible punch-ins. Monitoring is done off the playback head at all times so that when the bus is monitored it is displaced in time by two frames (universally, the distance between the record and play heads).

When the sound is monitored, it is heard as a combined mono signal coming from the center of the projection screen. The monitor system is usually comprised of a bus/mag selector, a bus (track) solo system, switchable Academy equalization, and a mute and level control.

DOLBY STEREO

With Dolby stereo mixing, the personality of the console changes considerably. This may be noted in the change of bus functions.

With mono sound tracks, the buses are used for the discrete combination of music, dialogue, and effects, whereas in Dolby stereo the buses are used for relative location assignment instead. What this means in practical terms is that no longer is the film mixer afforded the luxury of building the discrete bus, which can later be changed with relative ease. Instead, the sound effects must be married to the dialogue. The music level is no longer handled with a sub-master, but is mixed pretty much as in a record production.

The four tracks used in Dolby stereo are left, center, right and surround. When recording in the Dolby format, the console is the same one that was used last week for a mono production. This means that what was last week's music bus (track 2) is this week's hard-center soundtrack. The efficiency of the change of roles is determined by the flexibility of the console and the imagination of the operator.

Before looking at the console in greater detail, perhaps it would be a good idea to review the basics of Dolby stereo. First of all, mono films are optically striped with a single track on one side of the film. The Dolby stereo optical track is different in that, like a phonograph record, each side of the optical track carries different information. Dolby has also made significant changes in the way we “see” motion picture sound. The differences are that noise reduction is used on the playback of the optical track, and one-third octave

Greg Hanks, formerly service manager at Audio-techniques, Inc., formed New York Technical Support Ltd., which specializes in studio installation and service.

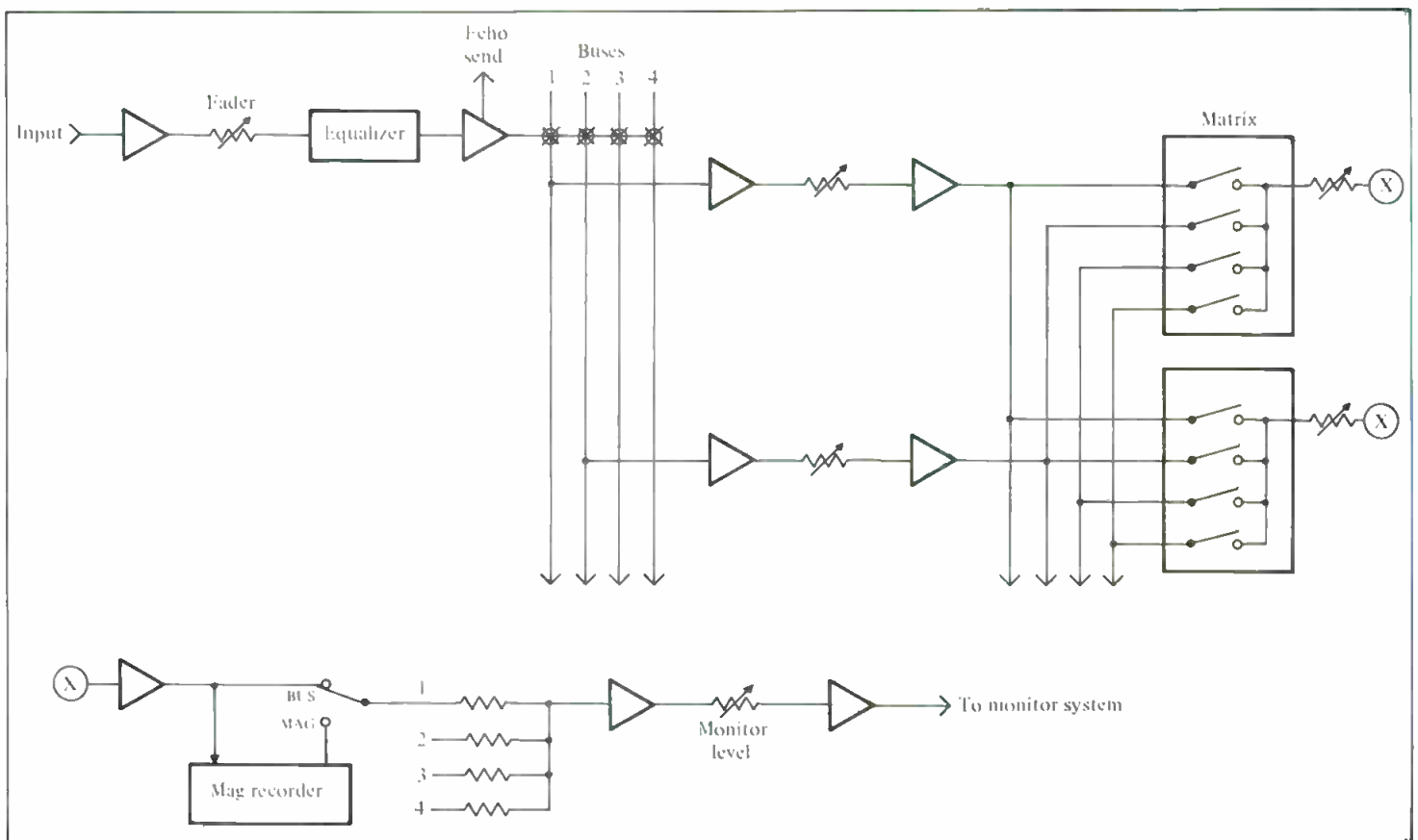

Figure 1. Console block diagram.

equalization is used in the theater playback system. The Dolby four-channel sound is encoded into two channels, using a phase-matrix system.

During playback, the signal is decoded with either a Dolby CP50 or a CP200. After decoding, the signal is sent to four one-third octave equalizers (required as part of the license agreement to show Dolby films), and then to the power amplifiers.

In the film studio, the encoding process for this four-channel system is handled by a unit called the DS-4. The Dolby DS-4 does much more than just encode four channels of information to two channels. It is a vital part of the recording studio chain during the entire mixing process. Because the matrix encoded uses phase information for directional cues, the matrix decoding is somewhat touchy when it comes to some source material. For this reason, all monitor signals are first encoded and then decoded before getting to the monitor amplifiers in the studio. The DS-4 does all this, as well as providing a mono compatibility check and additional metering inside the encode/decode chain.

The job of the classic film console is easily defined as a system that will combine many (up to and exceeding 56) sources on three or four different buses. As noted earlier, the standard configuration is dialogue, music, sound effects, extra effects.

Each input module usually provides:

- a channel fader,
- equalization (usually of the stepped type to accommodate repeatable settings),
- PFL and/or Solo, usually pre-equalization,
- discrete (usually, one to four) bus assignment. At times the send buses are ganged with the main assigns to marry the effects send to the main track.

The buses are usually sub-grouped, with the return of the married send buses returned before the sub-master. The groups are matrix-selected to the different tracks of the mag film recorder. A board master is most commonly provided.

The monitor section of the film console provides:

- mono fold-down of the four tracks,
- Academy equalization of the monitor output.

- bus/mag selection for the four tracks/buses (pre-fold-down). Generally, this selector is a master selector for all tracks.
- track solo, which is a facility to solo the individual tracks,
- monitor mute/dim. This is an overall function.

A block diagram of the standard console is shown in FIGURE 1. As can be seen in the figure, a standard mono film console is a relatively simple device. With a little creativity in patching, almost any recording console can fulfill film requirements. The four buses could be the first four buses of the console. The bus/mag select of the monitor could be the multi-track monitor bus/tape switch. The monitor section of the console is set up with tones for unity fold-down to mono, and most consoles have some facility for track soloing. The effects returns would be brought back to the input modules, and the sends could use the second set of four buses.

When using a recording console for film recording, the important thing to keep in mind is that the pan pots should never be in the circuit and the monitor of the four buses that feed the mag recorder should be level-matched, never touched, and combined to mono in the monitor. Console crosstalk should be very low, and the noise of the input channels should allow for multiple passes through the board without any noise contribution.

This all sounds simple enough, and it is. At least, it is a very simple thing to do mono recording on a multi-track recording console. However, Dolby stereo is quite another matter.

Let's look at Dolby stereo requirements with a function-by-function description of the console.

INPUT MODULE

The input module should be able to send the signal (after the common facilities of level, equalization, etc.) to any one of four discrete buses in the mono mode, and send the same signal through a pan pot to the same four buses in the stereo mode. The panning should be left-to-right, left (or right)-to-center, left (or right)-to-surround, and center-to-surround. One essential aspect of the pan pot is that it must be down

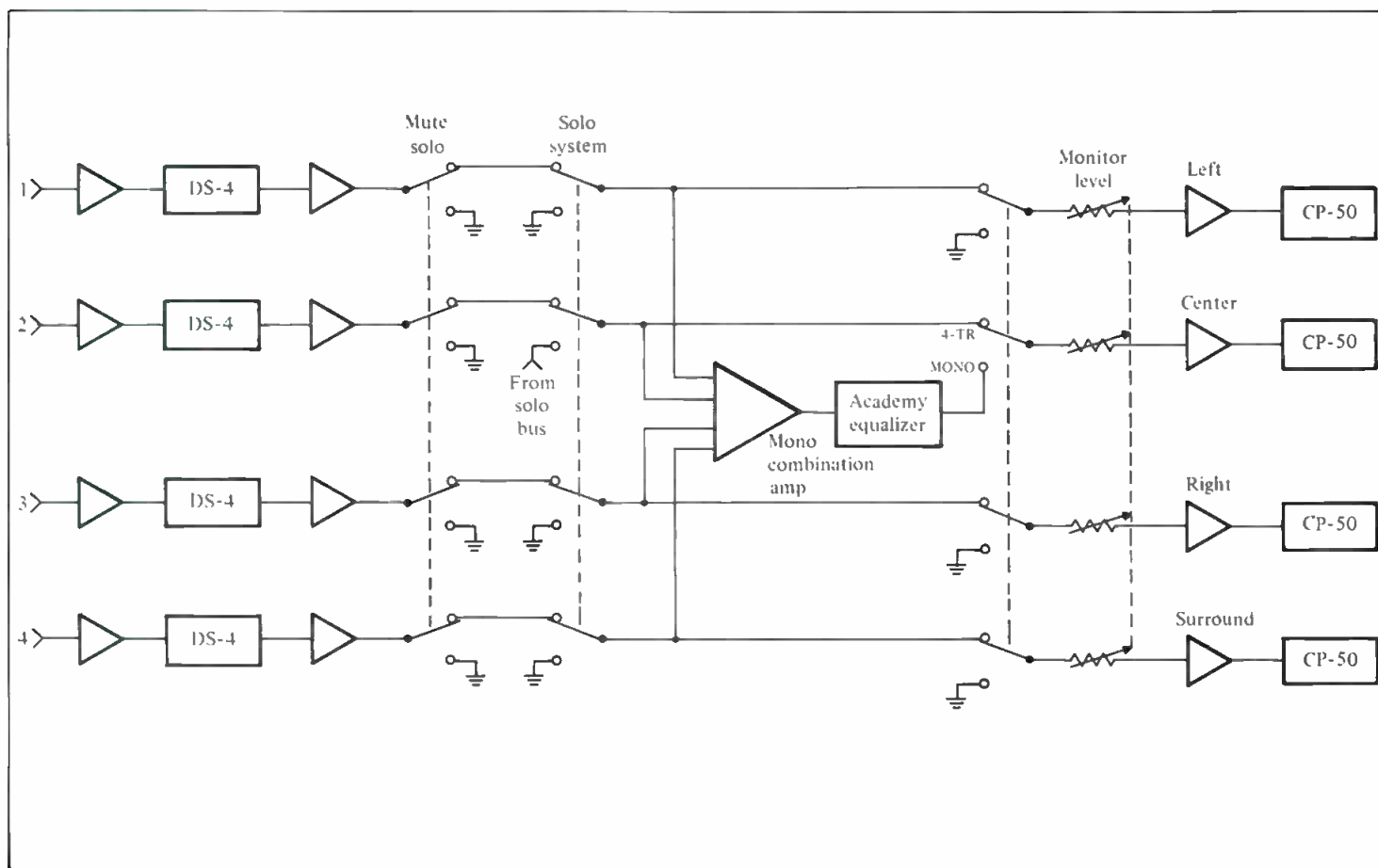

Figure 2. Monitor system detail drawing.

3 dB in the center: when the console is in the mono mode, the pan pot should be out of the circuit.

Discrete sends can be used interchangeably between mono and stereo modes. A minimum of four sends should be available. Something to note is that for 95 percent of the time the input modules are looking at line in, and a trim at this point in the signal chain is a very useful feature.

GROUP OUTPUTS

The group outputs in the mono mode should go through some form of sub-master that is accessible and easy to use. An overall board master should follow, and then the signal should go to the mag recorder (with metering and monitoring on the recorder side of the patch bay). However, for the stereo mode, the signal path must be broken between the console output(s) and the recorder input(s) to accommodate the Dolby DS-4 encoder. The outputs of the DS-4 then feed the recorder and the console bus monitor position. This function is usually accomplished within the patch bay of the console. The only real difficulty is to break off the bus monitor point within the console and make this an external function.

MONITOR

The monitor circuitry needed for Dolby stereo film (see FIGURE 2) requires a bit more than is readily available within the standard recording console. The requirements are:

- to be able to monitor the bus as an external function, as mentioned above.
- to be able during stereo recording to select bus and mag and send the selected signal at a +4 level to the FROM RECORDER inputs on the DS-4.
- to be able to return the monitor signal from the DS-4 output and insert it into the monitor chain before the individual channel mute/solo system, and before the master level control, mono check, and Academy equalization.

COMMUNICATIONS

The film post-production re-recording process is one of mixing and therefore requires very little in the way of communications. The only exception is the communication required between the projector operator, the machine-room operator(s), and the mixer. Most film studios are built with the projector directly behind the mixing theater. In a larger facility, or in one that maintains more than one mixing theater, there is usually a central room in which the dubbers and recorders are placed. In this location there is at least one person who changes patches, reels, and framing on the machines. Some form of internal phone-type intercom must be incorporated in the console system to allow for communication between all these facilities.

Sometimes the mixing theater will be used for live mixing or dialogue replacement. At these times, it is necessary for the standard talkback and cue facilities to be in place. Slate tones, and slate inject of voice on bus are also necessary for smooth operation.

MACHINE REMOTES

For any type of production facility, the requirements of machine control are directly proportional to the importance of ease of operation. With most studios this means that the direction controls of forward, stop, reverse and record, as well as individual track record on and off, are necessary. Other controls that are handy to include in the remote control package are inching, 2x (4x, etc.) speed, and shuttling. Something to note is that most mag machines do not have fast forward or rewind in their vocabularies. Inching is the capability to move forward or back one frame at a time. 2x means double speed, and shuttling is the same thing as MVC.

As can be seen, most professional recording consoles can, with a little modification, be applied to the re-recording process for Dolby stereo film production work. In the second part of this feature, the case histories of two such consoles will be described.

The following sidebar was written by Mel Zelniker of Sound One Corp. Mel is one of New York's more prominent film mixers. This is often given to clients preparatory to their coming to the mix.

Mixing Tips for Dolby Stereo

In today's world of production deadlines and squeezed budgets, the preparation and completion of a Dolby stereo mix represents a formidable task for both editor and mixer. On the East Coast, where film mixers usually work on mixing desks designed for single-seat flying, it is of paramount importance that the prep work done by the sound editorial team be organized in a most efficient manner.

For obvious anatomical reasons, the mixer is not going to handle the entire track inventory for each reel at one time. He is going to pre-mix. How these premixes are organized can spell the difference between a smooth creative mix and a battle.

As in traditional stereo, a signal sent equally to left and right is perceived as mono or "phantom center." In very wide theaters the phantom center may present perceptual problems to the viewer seated very far off the center-screen axis. Keep this poor guy in mind; we will get back to him in a moment.

The first premix will be for dialogue. We have found that it makes things neater if certain effects textures are added during the dialogue premix. Most of the time, the dialogue is going to come from channel 2 or hard center. We have found that the production "room tones" that are used to fill editorial gaps in the dialogue track work best if they are also sent to hard center. The same applies to "production effects," i.e. those effects actually recorded while dialogue action was taking place. In traditional mono editorial technique, these are usually split off onto the effects track of the master. In stereo however, we have found that for the off-axis viewer the sound "images" more realistically when sounds made by center-screen action come from hard center, as opposed to phantom center. For this reason we lay out our dialogue pre-mix as follows:

Track 1, dialogue.

Track 2, alternate dialogue and/or dubbing lines.

Track 3, production effects.

Track 4, room tones. In the final mix these all go hard center.

In addition, we will at times also lay down the Foley tracks along with the production effects.

Now the fun begins. We begin our stereo pre-mixes. We generally approach effects first. There is no cut-and-dried rule of thumb here. Atmospheres such as sea shores or airport backgrounds work wonderfully when recorded in stereo. In addition, the editorial staff will have prepared specific sounds to be placed left, right or on the surround channel. You can surround yourself in a jungle with monkeys chattering behind you, elephants on the right and birds on the left. It's all up to the imagination, and it's what makes a stereo picture sound so alive. But treat these pre-mixes with caution. If it isn't planned right, you can get trapped.

First, always have your dialogue premix up for listening purposes. We are able to monitor the premix while recording the effects premix. This allows us to

set an idea of the rough balances between the hard center and the stereophonic tracks.

Second, we like to break our effects premixes down to at least two units so that backgrounds from one scene are not butted up against the next scene. This involves editorial preparation so that these backgrounds are "checkerboarded." Later, when all the premixes are up and running at the final mix, you have the freedom to change the relationships from scene to scene without the need to do "on the frame" punch-ins.

Third, while it's possible to accommodate a certain amount of panning during these premixes, you can do a better job if the big action scenes with a lot of cross-screen panning are handled as a separate pass.

And fourth, treat the surrounds with respect. We never know how the surround channel is going to be set up out there in theatreland. It is the most variable aspect of any Dolby theater. Therefore, we have had the most success in treating it as a special effects channel. Experience has shown us that it is not smart to place constant information in the back of the theater. Also, for reasons best left to a more technical discussion, too much reliance on surround can do ugly things to mono compatibility.

At this point we have at least three pre-mixes available to us: the dialogue, and effects #1 and effects #2. We may have even more. Now comes the music. "Source" music (music coming from a radio or TV seen on the film screen), is generally mono. We place it in phantom center. The score is stereo, naturally. Nowadays it has become increasingly common to have the score divided into eight or more tracks for each cue. This is done because experience has shown that the balances achieved in the recording studio do not always prove to be the same when heard against dialogue and effects. Fletcher Munson, cinema equalization, and theatre acoustics all come into play. So here we are with Music elements A through E, some involving 12 faders, and the music department is asking for six cross-dissolves in 45 seconds of screen time. We're going to have to pre-mix again.

At this point, all things being equal, you are ready for that magic moment. Everything has been done right. Dialogue is smooth, the effects pre-mixes mesh one to the next, and your music is in manageable form. With an occasional hand from the people around you, the process by which all these elements come together begins. Soon you'll have the pleasure of seeing and hearing a Dolby stereo film. Mono just isn't the same.

It should be noted that this was written from the standpoint of a one-man mix. Rules are made to be broken and nothing is boilerplate. The organizational and editorial suggestions given here have worked for us. Any other suggestions would be appreciated.

• • •

As can be seen from the preceding paragraphs, film requires editorial coordination between engineering and production well beyond that expected in the record industry. ■

db Test Report

The Bruel & Kjaer Studio Microphones

BRUEL & KJAER INSTRUMENTS, INC. of Naerum, Denmark, have introduced a series of microphones designed for use in the professional recording studio. Audio professionals are already familiar with B & K's main product line, consisting of a complete spectrum of audio test equipment used for research and manufacturing. A look at the response curves supplied with your favorite microphone or at the polar curve of your monitor speakers will probably reveal that the equipment used to do the measurements was made by B & K. In fact, the majority of B & K's products are concerned with acoustic calibration. While it is not the point of this review to extol the virtues of B & K's sound level meters or Fast-Fourier Transform analyzers, it is important to note that the ultimate accuracy of these devices depends upon using reference-quality microphones. These microphones are called instrumentation microphones because they are inherently specialized for the purpose of making accurate measurements and not for making music. B & K's instrumentation microphone line consists of a dozen models, each specializing in different frequency ranges or different signal levels.

Within the B & K instrumentation level, it's no problem to find a model designed for the frequency range of 20 Hz to 20 kHz, and for levels from 20 to 150 dB SPL. In fact, there are two of them, differing in directional responses due to wavelength losses (to be described later). It would seem that such a microphone, designed to maximize frequency response and minimize noise and distortion, would be very transparent when recording music. This, also, is true. In fact, these microphones have been used to record several audiophile records and even some more-popular music, such as the Grateful Dead and the Charlie Daniels Band. However, unlike regular studio-type microphones, instrumentation transducers have several limitations for this type of application.

After the enthusiastic recording engineer shells out over \$1000 for each capsule and preamp, he must then build a device to deliver 200 volts to polarize the capsule and provide some other voltages to power the electronics. He is then left with a signal that is unbalanced and has a non-standard level, so he might as well build some mic preamps that can be located close to the microphones. The few engineers who go through this much trouble may indeed be rewarded with an excellent recording, but must still be prepared to cope with the consequences of using the microphone outside its designed environmental limitations. You see, instrumentation microphones are designed for a "controlled" environment. Location recordings are usually done in places where the environment (notably temperature and humidity) cannot be controlled. Even in the recording studio, an instrumentation mic could not survive the humidity or cigarette smoke from a close-mic'ed vocal any better than it could survive being whacked by a mis-directed drumstick.

The first obstacles to overcome were the environmental ones. It was obvious to B & K that an electret element, having no polarization requirements, and with the ability to withstand environmental extremes, was the solution. However, electrets have had other difficulties that precluded

them from being laboratory quality. Electrets are not inherently inferior, but there were many technological obstacles to overcome to raise the electrets to the quality level of the polarized condensers. Nevertheless, B & K set about the task a few years ago, and produced a series of capsules designed to retrofit the polarized ones—and do so at a cost savings.

Being sensitive to the needs of the recording business, B & K directed their efforts toward producing a series of microphones that would be compatible with recording studio line requirements. The result of these efforts are the microphones reviewed here. This series consists of four microphones. Two of them, models 4003 and 4006, have 16mm capsules while the others, models 4004 and 4007, have 12mm capsules. The smaller diameter version is capable of extended high frequency response, better transient response, less distortion and truer omni-directional characteristics. All this is obtained at the expense of sensitivity. For each microphone diameter, there is a choice of powering sources. Types 4006 and 4007 are standard P48 phantom compatible. Types 4003 and 4004 use a separate power supply, type 2812, that eliminates the transformer, operates the electronics at higher voltages for increased headroom, and supplies a line-level output that is less sensitive to capacitive loading and can deliver a balanced or unbalanced output. Although these types also use standard XLR-type connectors, the cable run between the microphone and supply should be kept fairly short because the signal here is both unbalanced and low level.

THE MICROPHONES

Each microphone comes with a high-quality mic cable and a sturdy mahogany case. Included in the case is a foam windscreen, mic stand adaptor and, of course, a very thorough calibration chart. Each microphone is individually measured for frequency response, sensitivity and self-noise level. The 16mm microphones also include a replacement protection grid with a different slot pattern in it. The purpose of this grid is to correct the frequency response when the microphone is used in a diffuse sound field. At 0 degree incidence, the diaphragm is presented with only one compression or rarefaction (see FIGURE 1). Therefore, no cancellation is possible. But all microphones of finite size are subject to the effects of wavelength loss when a wavefront presents the diaphragm with more than one compression or rarefaction at a time, causing some cancellation of the signal as measured by the microphone. This effect is more pronounced as the diameter of the diaphragm is increased and the cancellations begin occurring at lower frequencies. On-axis signals will always sound brighter than off-axis ones, but the selection of the proper grid gives the microphone either flat response to on-axis sources, or flat response over an average of all angles of incidence. When using any microphone for distant mic'ing where reverberation becomes a significant part of the signal, or for close section mic'ing, it is best to use the latter grid and orient the element at 90-degree incidence.

Most seasoned engineers are familiar with this phenomenon and adjust the incidence angle to fine-tune the high frequency balance of the sound, especially since many popular studio microphones have capsules that can be as large as one inch in diameter. The fact that B & K is

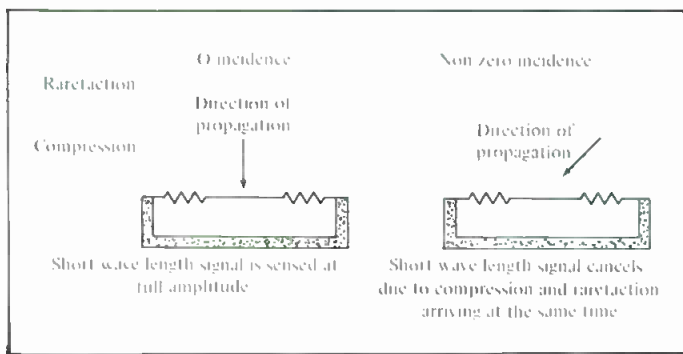

Figure 1. Effects of wave length loss due to compression and rarefaction at 0 degree and non-0 degree incidence.

concerned enough about this effect, in spite of the microphone's relatively small size, shows how meticulous they are in their efforts to put the microphone's performance at the cutting edge of technological capabilities.

Unlike their instrumentation cousins, these microphones have a satin black finish that will make them less obtrusive during a performance. The casing is also gently tapered to match the connector diameter to the capsule diameter to avoid sonic colorations that are caused from waves being diffracted or reflected off the housing.

SOUND AND SELECTION

After considering the thorough and exacting design process that resulted in this series of microphones, and examining the specifications that suggest the performance level to be expected, it comes as little surprise that they sound very neutral and transparent. In fact, every person I know who has tried them has commented that they seem to lack a sound of their own. Recording engineers, in general, collect an arsenal of microphones, each known for its unique colorations. In fact, it is not uncommon for a studio to have a quantity of microphones that outnumbers the available inputs by a factor of ten (well, maybe two). The reason for this is that the engineer needs to be able to make a selection based on the adjectives the producer is looking for. These people may initially find it difficult to find a niche for the B & K studio microphones. It's also interesting to note that, despite the fact that there are many microphones in the studio, chances are the only single-diaphragm omni-directional microphones around are the ones in the telephone, the console talkback and, perhaps, a cheap lavalier. There is a reflexive response among engineers to grab a cardioid microphone in the interest of minimizing leakage. A figure-eight pattern would also be acceptable if a ribbon element is used, but in general, omni microphones are avoided simply because of their lack of directionality. It is true that omni mics are generally found as the manufacturer's bottom-of-the-line selection. This is because an omni element requires no porting and is therefore easier and cheaper to design and manufacture.

The use of omni-directional microphones deserves a revival such as the one for direct-to-disk recording. Given a pair of microphones, one omni and one cardioid but otherwise identical, the omni microphone would have several inherent advantages. First, omni diaphragms are more highly tensioned because they cover an air cavity that is closed. This means that the diaphragm will not bottom out as easily. In fact, distortion in general is lower for this reason. Wind and break noise as well as "p" popping is almost nonexistent because omni mics sense only sound pressure and ignore velocity. The closed airspace behind the diaphragm would theoretically allow the microphone to have flat response down to DC. In practice, however, a small air leak is allowed, to prevent the microphone from acting as a barometer or exploding in airplanes. Still, low frequency response is generally smoother as well as more extended. Omni mics are also very insensitive to handling noise, so shock mounts are usually unnecessary. This is one reason why lavaliers are omni-directional.

Another unique advantage is that the omni pattern is the only microphone pattern that is immune to proximity effect. This means the engineer has more options available for placement, and can even regain the separation lost from using a non-directional pattern by simply moving in closer. Conversely, when used for distant mic'ing, instruments don't sound thin and disembodied.

All cardioid microphones built from a single element require some sort of porting arrangement that allows waves from behind the microphone to enter and cancel at the diaphragm. Since this is dependent upon path lengths and wave lengths, it is very difficult to design a porting arrangement that is broadband. The result is a polar response that varies substantially over frequency. This leads to an off-axis frequency response that is very uneven and, at best, attenuated only 20 dB with respect to an on-axis signal. This property is probably the dominant factor in the microphone's coloration. In fact, I usually evaluate a cardioid's sonic character by rotating it 180 degrees and listening to how this effects the tonal balance. While the microphone is obviously intended to be directed toward the sound source, reverberation and leakage will reveal the unique "fingerprint" that the microphone has. The porting also causes resonances that result in uneven on-axis response.

Despite all this, microphone selection is usually based on other criteria. It's ironic that great pains are taken to use low-distortion transformerless consoles and recorders tweaked for flat response within a fraction of a decibel when most of the time kick drums, for example, are picked up by mics that were designed twenty years ago and can be found in any musical instrument shop for less than \$100. Personally, I prefer to use a higher quality microphone, and when resonances or dynamic range changes are necessary I can go to the effects rack and obtain them without the side effects. Don't write in about this. I already know I am in the minority and I can't argue the fact that the only way to get the nasty sound of an \$85 microphone is to buy an \$85 microphone and use it.

CONCLUSION

Still, I like to encourage experimentation using these microphones in situations that are not traditional. I have loaned my review samples to two recording studios who have used them with great success in distant mic techniques, but have not yet tried close mic'ing with them. I have used the small diameter version with excellent results. On kick drum I got an explosive sound with bass that would flap your pant legs without sounding boomy. It's easier to limit the signal and filter it than it is to do the opposite on a cheap mic. Snare drums are crisp and percussive. Vocals are exceptionally good, with clean sibilants and freedom from plosive overload. The mic can be moved in close for as big a sound as you can stand without a trace of chestiness from proximity. Brass instruments are sharply focused without false brightness from distortion products.

I have used the large diameter ones for more distant work where levels tend to be a bit lower and noise level becomes an important consideration. Besides being very clean and transparent, reverberation is not colored. Applause sounds very percussive and it's very easy to hear individuals clapping without the garbled crowd sound that I have become accustomed to hearing from some other high-quality mics. I should also note that, when used in stereo, imaging is solid and precise, thanks to a close match in phase and transient characteristics.

Of course you don't have to take my word for any of this. B & K does not solely rely on slick Madison Avenue brochures to sell their products. If you want to find out for yourself about the mics or any other B & K products, all you need to do is contact the local representative who will be happy to set up a demo at your studio with some samples. You will probably discover your representative is not so much a salesman as someone with a solid technical background in instrumentation. You will probably also find out why B & K products tend to sell themselves. ■

Long Players—Long Gone

The following historical sketch focuses on the earliest days of the LP

AS PART OF A REPLY to a letter from F. G. Greenberg in the December, 1982, issue, db issued a request for information about the very earliest days of the LP at RCA or elsewhere. As many of you may know, I have collected apparatus and information related to the subject of sound recording over the past fifty years. In fact, I had considerable exposure to the RCA Victor Long Playing record project (as an observing teenager) when it was trying to learn to fly.

Therefore, this should be a good time to contribute some commentary on this apparently elusive subject before I, or others of my vintage having memories of it, are no longer on the scene.

Much of this historical sketch may be verified by observation and photography of items in my collection. As a matter of fact, as I write this I have just finished checking the playing time of a most remarkable phonograph record developed by Mr. Edison and marketed in 1926. It is a 12-inch disc employing vertical modulation, running at 80 rpm and—*Aha!*—it just ended one side after 21 minutes! Calculations show that it has 450 lines per inch. (Note I do not say grooves per inch—there is only *one* groove on each side of a record.) May we safely say there was a “super-micro-groove” record marketed before there ever was any “Micro-Groove,” and that Long Playing doesn’t necessarily mean 33 $\frac{1}{3}$ rpm?

Edison’s long player was destined at the outset to be a disaster. He hated anything to do with amplifier tubes (NIH?), and insisted on recording acoustically at reduced volume level while everyone else was into electrical recording at higher volume without that tin horn sound. If that wasn’t enough, the diamond stylus kept jumping grooves and tearing up the record surface.

With this the 80 rpm exception, all subsequent development of long playing records incorporated the record speed of 33 $\frac{1}{3}$ rpm. Why this speed?

THE 33 $\frac{1}{3}$ rpm DISC

Bell Labs, having been fully involved in the development of electrical phonograph recording, was now interested in adapting this apparatus to the motion picture. There was a prevailing lack of confidence in photographic methods of sound recording, and the disc promised to be a practical alternative, *if* the playing time could be increased to match the maximum running time of a reel of film—eleven minutes.

After careful analysis of the problem, it was decided that a 16-inch diameter disc, running at 33 $\frac{1}{3}$ rpm, would be the optimum record format. The groove pitch could be selected from three provided on the special recording lathe, 86, 92, or 98 lines per inch, all typical of what had long been employed in phonograph work. The system used the standard 78 rpm groove shape and changeable steel needles. Masters were cut from inside to outside of the disc and pressings were made in high quality shellac, the same material used for phono-

graph records. A new steel needle could easily trace the higher frequencies at the inside of the disc where the velocity was lowest. As the needle point wore off, the groove velocity increased toward the outer edge of the record, effectively compensating for the high-frequency losses that otherwise would be most evident at the moment of changeover from reel and disc to reel and disc. Naturally a new needle was used at the start of each playing and the label had a series of numbered blocks which were to be checked off with a pencil at each playing. After all blocks (typically 20) were checked, the record was to be discarded. Such drastic wear of the record was caused by the weight of the oil-damped pickup, which was about four ounces.

With the simple refinement of increasing the groove pitch to 125 lines per inch, a full 15 minutes could be recorded, and thus was born the “electrical transcription” for radio broadcasting. These records were initially syndicated fifteen-minute or half-hour programs widely distributed to independent stations not affiliated with land-line networks. Again, they were pressed in shellac. The necessity of using wax for recording made recording at individual stations highly impractical until the introduction of the lacquer-coated aluminum disc.

By 1931 RCA Victor had completed design and began manufacture of apparatus to play a form of 33 $\frac{1}{3}$ rpm disc in the home. It was introduced with a highly impressive press demonstration on September 17, 1931. The complete Fifth Symphony of Beethoven was played from a single twelve-inch disc, where a previous 78 rpm version of the same work in the Victor catalog required five discs. Obviously Victor had done something more than change speed. With standard grooves, 33 $\frac{1}{3}$ rpm would have given only 2.34 times the playing time of a 78 rpm disc. These records had a much finer groove, with 150 lines to the inch, and they were pressed in a plastic material which RCA had been using for a time in pressing 16-inch records for radio broadcast. It was called Victrolac. I have several of them in my collection and they look and feel very much like today’s records.

VITROLAC

Because the groove was closer to Micro-Groove than standard, a special chromium-tipped and highly polished needle was employed to play them. It had an orange colored shank for identification. Standard 78s were to be played with a green shank needle, chrome tipped with a more rounded tip. Woe be the Victrolac if one failed to change to the proper needle when changing from 78 to long-playing record!

I well remember the fragility of these records and other factors conspiring to bring about their destruction. All RCA Victor pickups at the time were of the magnetic horseshoe configuration, mounted on the famous “Cobra” arm seen in FIGURE 1. The wings contained lead weights intended to keep the entire assembly free from rotational vibration when excited by low frequencies—a somewhat futile attempt at improving the low frequency signal output. The mass of this assembly and its weight caused merciless wear of the plastic records and if perchance one bumped against the



Figure 1. RCA Victor radio phonograph, 1931 model. After playing, the record was dropped onto the top of the stack and a new record was peeled from the bottom. It played 78s and Long Playing records, but only one side of 10 inch size. 12 inch records were played manually. Notice the massive size of the "Cobra Arm" pickup.

cabinet the needle was sure to jump the groove and skate to the center of the record, completely ruining it. The instrument illustrated in FIGURE 1 placed played records on the top of the stack and scraped the next to be played from the bottom. Users soon found that this was no way to handle plastic records. At a cost of higher background noise, some records were actually pressed in shellac, and of course these were much more hardy.



- Opera
- Symphony

RCA VICTOR Record Player

Now you can hear the music you want, when you want it, with this sensationally low-priced RCA Victor Record Player. It is electrically-driven and can be attached to any radio in a "jiffy". It enables you to hear through your radio the marvelous reproductive qualities of "Higher Fidelity" Victor Records. Hear

Figure 2. Inexpensive attachment for playing 78s. Push-to-start motor would run in either direction. Notice the reference to "Higher Fidelity" records. This was in 1935.

TURNTABLE DRIVES

Around 1935, RCA introduced a nifty inexpensive player as an attachment to radios in order to play 78 rpm records. It used a bi-directional salient-pole synchronous motor—the only such device I experienced for home use. FIGURE 2 shows a reproduction from an advertisement for this unit. In a very small nicely finished walnut wooden box, with separate cover, a short-arm pickup and a tiny turntable

**What business
does a handsome dog
like me have
with a
top cat
like
you?**



My name's McGruff,™ and it's my business to help prevent crime. I think it should be your business, too—to teach your employees how to protect themselves. Just send for my business kit—it'll help you develop a program that teaches your employees how to make their homes burglar-proof, make their neighborhoods safer, even how not to get mugged.

So take the time, and...

**TAKE A BITE OUT OF
CRIME**

Write to National Crime Prevention Council, 805 15th St., N.W., Washington, D.C. 20005 for lots of information on Crime Prevention.

Ad A message from The Crime Prevention Council, this publication and The Ad Council. Council © 1983 The Advertising Council, Inc.

Whisper Glide™

The "High Performance"
fader that "FEELS"
as good as it sounds

WHISPER GLIDE . . .

The new name in professional audio faders. Absolutely the SMOOTHEST action in faders available . . . AND . . . with superior MystR® conductive plastic elements. Continuous, computer-generated, noise-free output functions provide excellence to the serious audio professional.

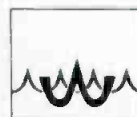

Waters Manufacturing, Inc.

Longfellow Center,
Wayland, MA 01778
(617) 358-2777 - (617) 893-6900.

Available in 100 and 65 mm lengths . . . linear, modified audio, logarithmic tapers. The SMOOTH choice for Broadcast and Recording Mixer Service. Even the price "FEELS" good.

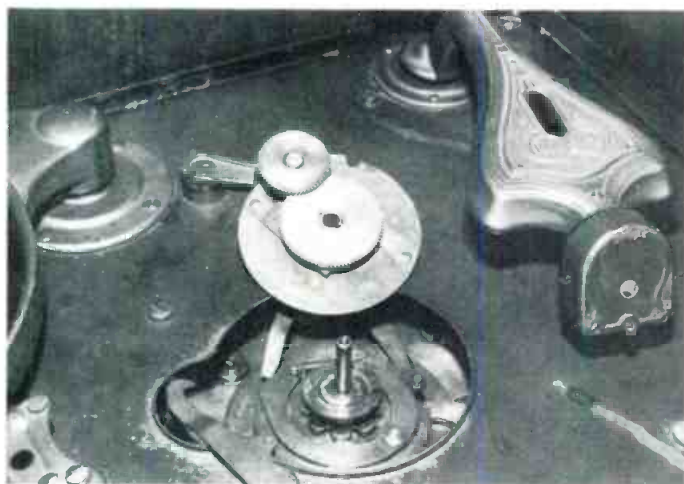

Figure 3. Planetary reduction gear assembly used in the first models of two speed drives for home radio phonographs by RCA Victor.

was mounted. The illustration shows a 10-inch record in place. It could play 12-inch records of course, with horrible tracking error at the start of the record, but nobody worried much about that in those days. The motor was extremely simple. A stator containing the exciting coils facing outward was surrounded by the rotor rigidly mounted to the underside of the platen. The rotor had 92 teeth projecting inward and matched to teeth projecting outward from the stator. With 60-cycle current applied to the coils, the rotor would lock at 78.26 rpm when started by hand in either direction. The Saja motor was a much more refined version of this drive, available either in 78 or combination 78 and 33 $\frac{1}{3}$ versions, and had been manufactured in Europe for several years.

Such turntable drives were anticipated some time earlier by the Western Electric 203A Reproducer Set, introduced in the 1920s. This contained two 78 turntables and oil-damped pickups for use in radio stations and for intermission music in theatres. The motors were made by Crocker-Wheeler and employed a direct-drive eddy current copper disc 12 $\frac{1}{2}$ inches in diameter to accelerate the rotor to sync speed whereupon the salient-pole rotor and matching stator locked the speed at 78.26 rpm.

However, when RCA introduced the Long Playing record to the home market, this type of motor was not used at all. All of their machines that I ever encountered used a conventional shaded pole or capacitor synchronous motor with an 1800 rpm rotor locking on speed either by having a salient pole or hysteresis rotor. The rotor shaft carried a worm-and-thrust bearing at one end. The worm drove a helical gear on the turntable spindle. In all cases the latter shaft ran at 78.26 rpm.

In the earliest version, a planetary assembly, shown in FIGURE 3, was slipped over the vertical shaft. The shaft end, projecting through the assembly, supported the turntable platen. A shift lever (FIGURE 4) allowed this entire assembly and the turntable to rotate at 78 rpm or immobilized the frame of this assembly. The turntable was then driven through the reduction gears at 33 $\frac{1}{3}$ rpm while the shaft remained running at 78. In a recent test I performed on one of these drives I found the wow-and-flutter to be intolerable at 33 $\frac{1}{3}$ rpm. It was indeed a very poor design.

Within a year or two a much improved drive was introduced. The design was patterned after RCA's very successful two-speed turntable intended for professional broadcast use. The home version was simple and inexpensive and performed remarkably well. It was also capable of being fitted to earlier single-speed radio phonographs, although RCA does not seem to have done much to press this feature. The entire two-speed apparatus was built into the bottom

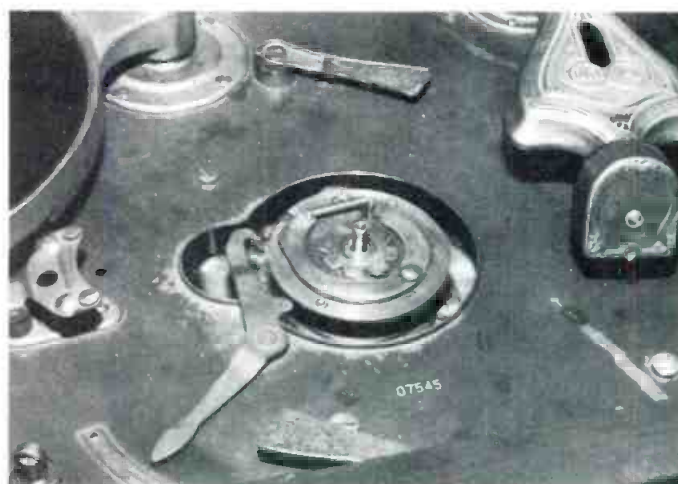

Figure 4. Drive assembly in place on vertical drive spindle. Note the shift lever used to catch and immobilize the planetary reduction frame to attain 33 $\frac{1}{3}$ rpm.

of the turntable platen. It is shown in FIGURE 5 with its small dust cover removed, revealing a ball-bearing type assembly containing only three steel balls. The 78-rpm drive shaft from the motor is keyed to the slotted hub which also provides the inner ball race. The small lever attached to the outer ball race is spring loaded so that one of its ends rests in one of four notches in a ring rigidly attached to the turntable platen. The balls are equally spaced in their ball cage, which is also rigidly mounted to the platen. In this situation the entire assembly, including the platen, rotates at 78 rpm.

An external two-position slide, mounted on the motor board and not shown in the illustration, clears the little lever on the outer ball race when it is in its outer position; when advanced to its inner position it catches the free end of the lever and entraps it. This causes its other end to be lifted out of the notched ring and hold the outer ball race stationary. Since the balls now roll around between the inner and outer races, they cause the ball cage and the platen attached to it to rotate at 33 $\frac{1}{3}$ rpm.

Because there is very little freedom and no gear teeth in the system, the drive is capable of remarkably low flutter-and-wow. Transmitted rumble, of course, is another matter. To the best of my knowledge, this drive was used right up to the time that the entire project was abandoned.

I had the opportunity to test many two-speed drives of other manufacturers and found most to be quite unsatisfactory. Most attempted to drive the turntable shaft directly through small shiftable gears from a worm on the end of the

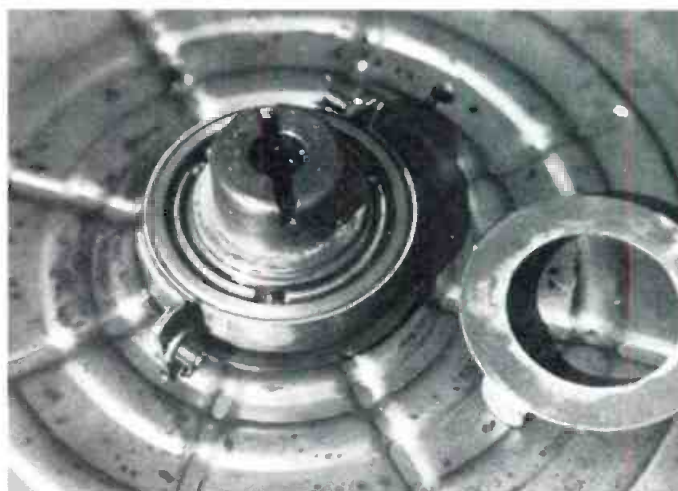

Figure 5. Three ball planetary speed reduction assembly built into underside of turntable platen. The entire unit is only 1 $\frac{1}{8}$ inches in diameter.

motor shaft. This was similar to the systems already described, but invariably the flutter-and-wow was excessive, because of the bad ratio of small driven gear diameter to the twelve-inch diameter of the record table. This was a classic case of the mechanical equivalent of improper electrical impedance matching. One manufacturer tried to reduce the problem by adding weights to the periphery of the turntable, but this resulted in ferocious low rate hunting with consequent murderous loading of the worm and gears.

THE GARRARD APPROACH

Garrard of England circumvented some of these difficulties by approaching the problem in reverse order. Instead of using a high-speed motor to drive through a worm, the motor rotor was on the turntable itself. It was a heavy laminated-iron ring which surrounded a stator assembly comprised of thirty coils! This operated as a shaded-pole induction motor similar to the large old-fashioned ceiling fans which have recently come back into vogue. With so many coils the rotor would seek a top speed of 240 rpm. A quality helical gear at the bottom of the spindle drove a flyball governor through a worm. In this regard the design was almost identical to the spring-wound motors long used in acoustic phonographs, except that the gear ratio was much higher. This assured that the governor would be running fast enough at 33 $\frac{1}{3}$ to exercise good regulation. By merely moving the brake pad on the governor, the speed could be increased to 78 rpm. Speed change was accomplished by moving a lever that carried two adjustable visible calibration marks. Three rather serious deficiencies became obvious as soon as I installed one of these units. First, accurate establishment of speed and its maintenance was difficult and unreliable, particularly if one changed from one speed to the other and then back again. Second, at 78 rpm the rotational speed of the governor was so high that normal manufacturing imbalances of the flyballs caused excessive vibration of the entire machine at frequencies that were high enough to be heard through the reproducer and loudspeaker. Third, the relatively unshielded coils and their proximity to the pickup induced serious hum into the reproduction.

THE LONG PLAYING RECORD— WHAT HAPPENED?

The RCA Victor Long Playing records had a lot going for them. They cost a lot less than the equivalent music on 78s. There was public enthusiasm for the idea, and it was in the hands of an organization that knew how to sell, even in depression times. The catalog of available records grew to 175 in 1934.

Yet by 1940 there were only 8 records listed, all suitable for background music in funeral parlors. What had happened? Well, not the least of the problems was that recording fidelity was inferior to most 78s. After the initial demonstration record of Beethoven's Fifth, recorded directly to Long Playing disc, nearly all subsequent issues were dubbed from 78s. They just didn't sound as good, even when played on professional equipment. As a complicating factor, turntable motion was poor. It seems significant that out of 87 records listed in the 1936 catalog only one was of piano music, a Chopin Sonata.

Records were highly vulnerable to wear and destruction under the excessive needle forces, vertical and lateral, imposed by the massive pickups of the day. Furthermore, the rigid discipline demanded of the user to observe the type of needle to be used either for 78 or 33 $\frac{1}{3}$ records was almost certain to be disregarded now and then, with dire consequences.

Radio phonographs with the Long-Play feature were expensive, starting around 250 dollars—in depression days! And, RCA never did provide inexpensive adapters to permit enthusiasts to add the feature to existing equipment.

Of course, the tone quality of radio phonographs at the

time these records were introduced was enormously inferior to what would be acceptable today. While AM radio had a response out to 5 kHz, as it still does, radio manufacturers were convinced that listeners wanted a "mellow" sound. Such quality was best described as overly accentuated harmonic bass, the lack of fundamentals resulting in a "booming" sound, and a steep roll-off of the higher frequencies. There were often severe peaks and notches in the loudspeaker frequency response. The so called "power detector" was probably the worst source of distortion, although it ran a pretty close second to that generated by single-ended pentode stages without feedback! A convenient dodge around such sources of distortion was the initial roll-off plus the so called "tone control," that was always arranged to do no more than wipe out more highs. Truly miserable sound was everywhere, but salable to a market that had been acclimated to expect such reproduction.

RCA engineering follow-up to debug the Long Playing record seems to have been minimal. Other than the introduction of the planetary ball turntable, there seems to have been no effort to solve any of the above deficiencies.

The RCA Victor Long Playing record limped along and eventually died. It was a good idea but ahead of its time. In the mid 1940s, all the elements for success were in the wings ready to be joined in a practical, workable system: a light-weight pickup with permanent jewel needle intended—not to do double duty with 78s—specifically to match the requirements of the new system only. A good plastic material promising quiet surfaces was available, and an inexpensive two-speed turntable drive system, the inside rubber idler rim drive, was completely suitable for application in this service. All of these elements are still with us today in the "Microgroove" record and in the 45 rpm record.

But now, it's time for the digital disc. ■

Get Aligned Stay Aligned with STL precision magnetic test tapes

These dependable tapes are used by broadcasters, recording studios, equipment manufacturers, governments and educators throughout the world. Widest variety...Alignment, Sweep, Pink Noise, Level Set, Azimuth and Flutter/Speed. Available on reels, in cartridges and in cassettes. Also, the Standard Tape Manual & the Magnetic Tape Reproducer Calibrator.

Phone for fast delivery or free catalog.

STL

STANDARD TAPE LABORATORY, INC.

26120 EDEN LANDING ROAD #5 HAYWARD CALIFORNIA 94545 • (415) 786-3546

House Sound Reinforcement at the US Festival

Though the US Festival may have lost money again this year, it sure sounded good doing it.

FOR THE SECOND YEAR in a row, Apple-Computer-maker-turned-promoter Steve Wozniak has lost money. Too bad. But the US Festival was one great party for those who attended. And in spite of the inevitable minor inconveniences and clashes created by so many thousands of people in one place at one time, everyone had to admit that the sound was great. A twenty-one speaker salute to Clair Brothers (Lititz, Pennsylvania), the sound-reinforcement company that provided the 196-cabinet main system, and to Showco, Inc. (Dallas, Texas), the people in charge of the four delay towers that delivered music to the most remote corners of the concert area, is certainly in order.

Reinforcing one act right after the other for three straight tropical-temperature days, with smog thick enough to erase the neighboring mountains, was no mean feat. The smoothness of the overall presentation was a result of military-like precision preparation for the between-act set changes and state-of-the-art technology and design applied to concert amplification.

ON STAGE

"We had three bands—the one that was on stage, and the next two bands on the schedule—mic'ed up as much as possible all the time," explained Clair Brothers' chief engineer Mike Wolf, the man responsible for all aspects of the sound at the festival site. "At any time, there were three drums kits mic'ed. If a band had their guitar amps on risers, we had mics on them, too. We wanted to be able to roll the equipment into place, run a multicable-multipin connector over to them, and plug the whole thing in without wasting any time."

All the equipment changes in the sound system were completed early. The band was always mic'ed, checked out, and ready to go ahead of schedule. Said Wolf, "only a couple of set-ups went overtime, and that was because we were waiting for the band to get up on stage, or the band had a problem with their own gear."

The efficiency was due mainly to the pre-event planning. Mike Wolf got the information necessary to figure out the mic'ing set-ups in advance. Then again on the day of the show, when each band's representative came forward, Wolf asked for an updated list. "Most of the time, a band usually sends in an old microphone list. Or by the time they get to the

day of the show, they've probably switched something around. By getting new lists a couple of hours before each band went on, we were able to give them exactly what they wanted."

Because the festival featured so many different types of instrumentation, standardized mic'ing from group to group was not the smartest approach. At last year's show, the philosophy was to keep all the instruments in the same channels. For instance, the kick always went in one channel, the snare in another, bass guitar in another, and so on. But this year the procedure was easier and more efficient with microphone assignments worked out on a per-band basis—which is exactly what the musicians wanted anyway. "Some routing did remain the same, though," said Wolf. "Our patch to the recording truck was left in all the time with our channel #1 going to their channel #1 and so on. If they needed to repatch something, they did it within the truck."

Wolf divided his crew into four main groups of three or four people each: one group watched the amps; a second changed microphones; a third worked monitors, and the fourth stayed out in front at the mix position. The total number of crew members varied, depending on the needs for a particular day, but the highest number (16) was reached during the three rock days. (The US Festival schedule also included a single day of country music on the following weekend.) Wolf himself moved from one crew to another to ensure that everything ran smoothly.

SPEAKERS

Clair Brothers' main speaker system for the house was mammoth. The company brought in 180 of their S-4 speaker boxes, each containing:

- Two K-151s or 2240s for bass (18" JBL); 20 Hz-200 Hz, 18 dB/octave
- Four K-110s or E110s for mid (10" JBL); 200 Hz-1.2 kHz, 18 dB/octave
- Two JBL 2441 compression drivers for highs (some of the cabinets contain one JBL 2441 and one TAD TD-4001 compression driver); both drivers run all the way out on top
- Two JBL 2405s for super highs; 8 kHz and up

This four-way system is driven by a tri-amplification system of Phase Linear 700s.

Both sides of the stage held ninety cabinets apiece stacked three high in ten columns on three separate levels (see FIGURE 1). The first five columns nearest the stage on every level were arranged in basically a flat plane facing the

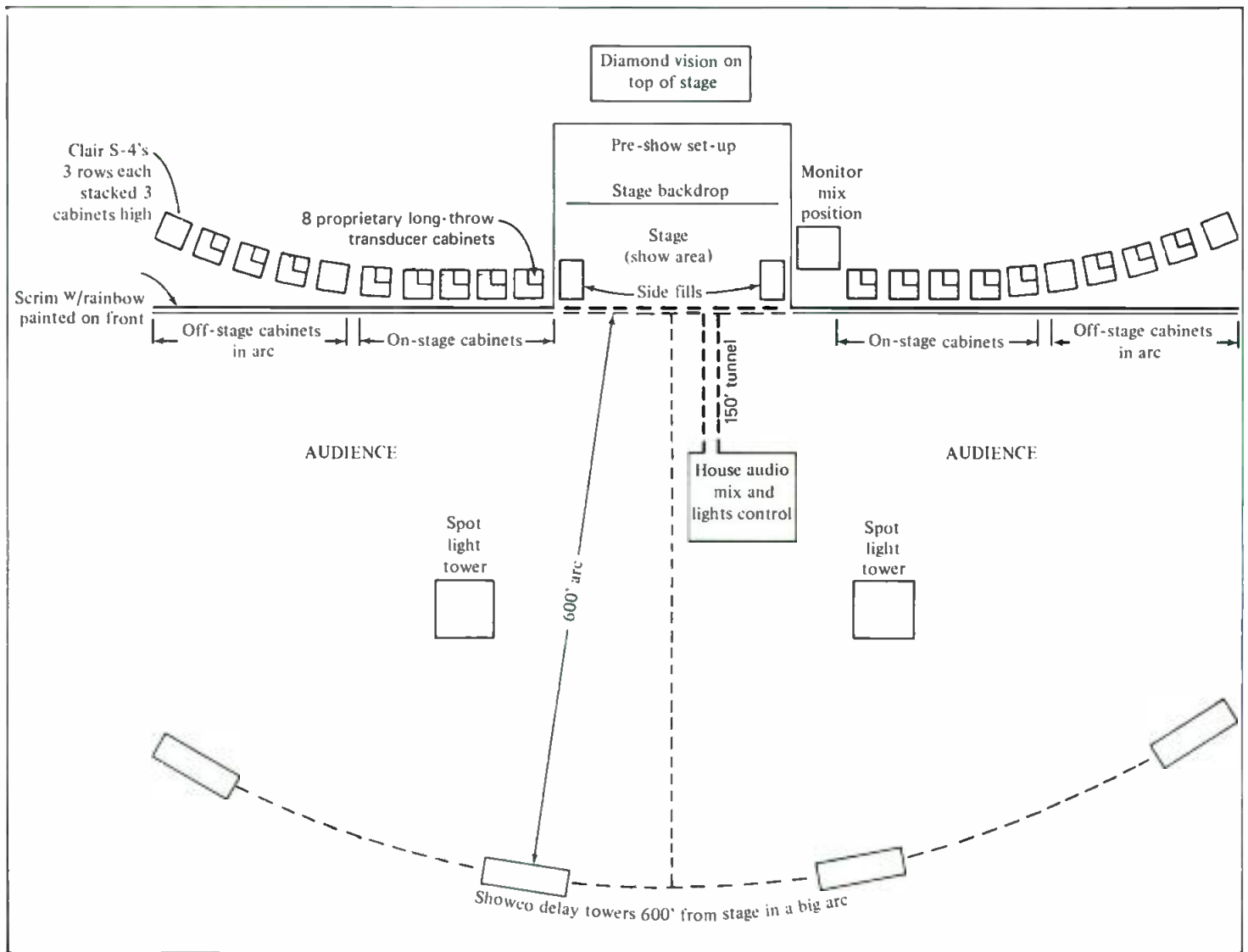

Figure 1. Sound reinforcement set-up for the US Festival.

crowd, while the furthest five were arced to the outside to cover a greater audience area. "You have some trouble with cancellation," noted Clair's veteran audio engineer Bruce Jackson, whose latest projects have included mixing the international Bruce Springsteen-marathon tours and Stevie Nick's 1983 summer tour, "but in such a massive array it just doesn't matter. You have so many peaks and valleys in the frequency response that the overall sound evens out."

Four Phase Linear 700 amps in one rack powered a set of four cabinets. The top amp in the rack drove the highs in four cabinets (two cabinets per side); the second amp down powered the mids in four cabinets, and the third and fourth amps fed the bass (one cabinet per side).

The days were so hot that the amps needed extra cooling. The racks themselves were configured in groups of four, with a single piece of insulation material enclosing all the backs. This had a flap through which to install dry ice to cool the amplifiers. "At the last concert we used a ridiculous amount of ice," remembers Jackson, "and the vendor realized he was the only supplier. The price went up from something like \$.25 to \$1.25 a pound. This time we supplied our own."

On top of the S-4 arrays were 16 proprietary horn clusters driven by SAE 2600s. "The compact cabinets and horns are our own design," explained Mike Wolf, "and are meant for long-throw applications. We had four horns in each of eight

boxes on both sides of the stage with one 2600 assigned to each cabinet. It was more of an experiment than anything else. We were really happy with the way they worked out."

OUT FRONT

The house-mix position (located about 150 feet from the front of the stage and just off-axis to house right) consisted of enough equipment for two complete Clair Brothers mix systems, plus a standard Showco set-up for two groups that had requested their mixing services. A special tunnel, comprised of buried concrete pipe sections, was installed to link the house position with the backstage area. The four-foot height provided just enough room for someone to waddle from one end to the other. Although it may have been uncomfortable, it was much easier than fighting through the human sea engulfing the stage area and extending back to the delay towers about 600 feet out.

The mic splitter on stage fed three 40-pair snakes that also ran through the tunnel. One fed Showco's console, and the other two ran into the system's main boards numbered "1" and "2" (see FIGURE 2). Except for the two acts (David Bowie and Van Halen) where Showco's board was patched into the system, all mixing took place via Clair Brothers' two custom-designed desks, which were totally independent of one another, yet linked through a master-control console

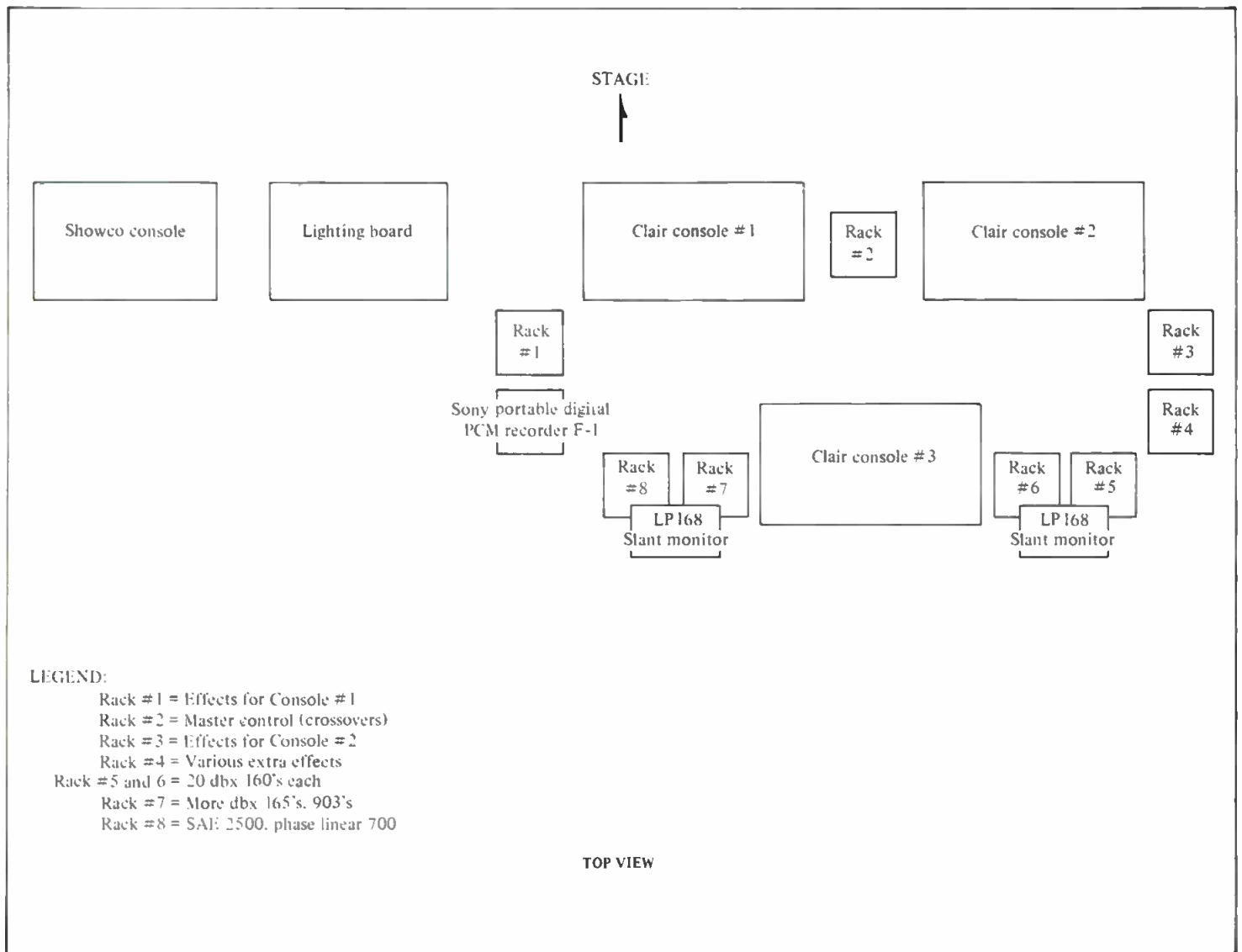

Figure 2. House-mix position and set-up.

(aptly named “#3”). Clair Brothers advisors (Bruce Jackson, Dave Kobb, and Rex Ray) were on hand to lend assistance to the bands’ audio engineers and make recommendations as to the immediate conditions of the system and microphones.

The general procedure allowed for one console to be mixing the act on stage, while the second was being adjusted for the following act that was being readied behind the backdrop. Each band’s sound engineer could prepare approximately the gain and equalization settings and play with the effects rack dedicated to his console. During set changes, fine adjustments were made via a two-way communication system.

Even though recorded music was played through the main speakers for the audience during set changes, the bands’ mixers could solo any instrument on a slant monitor located behind them at head level. They also were provided with a microphone routed through the stage monitors and sidefills. Because the volume was up all the time, they could talk to anyone on stage or kill the mic by simply flipping the on/off switch.

“The talkback mic was invaluable,” laughed Bruce Jackson. “We could usually never reach people on the intercom. But if they ignored us using this set-up, we could yell at them

especially loud. The stage crew also had the same kind of mic communication with us, so they could yell at us, too.”

The music playing between acts originated at the video truck. That division of responsibility was a contract provision to coincide with the video presentations on the Diamond Vision screen above the stage. The couple of times that the audio feed wasn’t coming through, Clair filled the dead air with recordings from their Sony PCM-F1 digital player.

MASTER CONTROL

The master-control console (#3) regulated the outputs from all three consoles (Clair’s #1 and #2 and Showco’s) and mixed them with the various feeds, such as those for stage communications, feeds to and from the video truck, satellite feeds for the show sent to the Soviet Union, and lines for several tape machines.

The output from console #3 would then go to the master-output rack (rack #2), located between consoles #1 and #2 and containing the basic crossovers and graphic equalization for the house system. The entire set-up was “tweekable.” The units in the master rack afforded the versatility to equalize each of the three on-stage and off-stage speaker-cabinet



Figure 3. A view of the stage during set-up.

levels on both sides of the stage independently at the low-, mid-, and high-frequency ranges. In other words, the bottom, middle and top levels of speaker cabinets each had their own unique equalization mix of low, mid and high frequencies. On-stage and off-stage sections were separately adjustable and the process was repeated on the opposite side of the stage. For example: less highs could be added at the lowest speaker level on-stage, yet simultaneously the highs on the top level could be boosted, while the second level of cabinets could remain at a nice balance somewhere between the top and bottom. That way, the people in the audience down front wouldn't be blown away by the sharp treble frequencies of the bottom row of speakers. But as the rows of speakers got higher (in height, not volume), the amount of treble coming out of those cabinets could increase to compensate for the longer distance the sound waves had to travel.

In turn, every crossover line had its own dbx 160 limiter/compressor (20 each in racks #5 and #6) that would catch any problems created by someone overdriving a part of the system.

REMOTE REINFORCEMENT

To retain the impact of the music produced on stage, Unuson (Wozniak's production company) hired Showco to augment the main system with sound reinforcement towers that covered the back of the audience area. Their four sound towers were positioned in a perfect arc 600 feet from the stage. Because the sound traveled faster to the tower via cable than through air from the source on stage, a delay was added to match the wave fronts and send out coherent program material. For the 600-foot distance, the delay time on their signal was set to approximately 540 msec.

Showco's four-way system contained JBL components, except for Yamaha tweeters on the high end. "Two cabinets make up our four-way," explained Showco's engineer Donnie Kretzschmar. "One is a bass box with three JBL 15" K-140s. Another cabinet the same size contains two JBL K-120s for mid-bass, two JBL 2441 drivers for mid-range, and two Yamaha tweeters for the high end."

Crown PSA-2s powered the transducers. Two low-end cabinets ran off one mono PSA-2; a mono PSA-2 drove two low-mids (K-120); and a stereo PSA-2 powered the mid-range with one side and highs with the other. According to Kretzschmar, the wattage per tower approached 24,000 watts.

FESTIVAL ENTRANCE REINFORCEMENT

Speaker manufacturer James B. Lansing (Northridge, California) loaned Unuson additional speakers to soothe and entice the music aficionados at the main gates while they waited to filter through the ticket-takers. JBL brought in 12 (four for each of the three entrances) 4680 Line Array column speakers. The cabinets incorporate four E-110 low frequency drivers and two 2402 bullet tweeters. Because the entrances were such great distances from the stage area, the UREI model 6500 amplifiers that powered the JBL columns were fed via microwave to eliminate as much cable as possible. The sound was very good.

In fact, the whole system was a joy to hear, with clear upper end and solid bass response throughout most of the show site. But if you missed the event of the year this time around, don't feel too bad. Rumors are already circulating that Woz may try again next year. Good luck. ■

Compact Disc Analysis

Author Tapes has taken what appears to be a novel approach in investigating the CD—listening to it.

AS A MEMBER of the professional audio community, and an avid music listener, digital audio technology is now part of my life. For the past several years I have been exposed to this magical process in the following ways:

1. by reading the various trade publications,
2. by attending digital demonstrations,
3. by attending recording sessions,
4. by listening to digitally recorded records.

For an investigation of digital as a viable (and musical) medium, the first three items on this list could well be ignored. They were intellectually enlightening, but my brain kept calling for an information input through my ears, not my eyes. The demos and recording sessions never really lent themselves to any purpose other than hype. My brain kept telling me to get out of those situations as quickly as possible.

That leaves item 4, the final product...the record, as the only true source for my evaluation of the digital recording process. After all, if the proof of the superiority of digital recording is not on the record, then what's all the fuss about in the first place?

My quest for the truth about digital has not been my only quest for truth in audio. Since my youth, I have been involved with recorded music on many levels—first, as a musician, a hi-fi enthusiast, a hi-fi repair-person, a hi-fi salesman, then later on as a recording engineer, a concert and radio producer, a pro' audio dealer, and eventually as a pro' audio designer and manufacturer. Through it all, I have always investigated and experimented with both the recording and playback of music.

As a result of this I have owned a few hi-fi systems in my time. The first was the typical starter system of the day: an AR turntable, a Dynaco SCA-35 (built from a kit, of course), and a pair of AR-4X Speakers. My present system comprises a Linn-Sondek turntable with a Linn Itok tonearm and Linn Asak cartridge, Naim Electronics (including pre-amp, crossover, and power-amps), and Linn PMS Isobarik Speakers.

To me, the above system represents the playback system that is most capable of satisfying my two basic musical needs. First is the out-and-out emotional pleasure derived from the music listening experience; second is the ability to extract all of the information stored on the playback medium (in this case the LP record).

Without going into a complete discourse, the folks at Linn (in England) have pioneered (no pun intended) the state of the art in turntable design. While other turntable manufacturers were building turntables that could reproduce test records with the best specs, Linn's founder, Ivor Tiefenbrun, was busy listening to music. He came to the conclusion that the specs derived by "testing" turntables had no relation to how music sounded when the record was played back. His proclamation to the world that "turntables sound different" was scoffed at. Now, some 15 years later, "high-end" turntables are often judged by how they compare to the Linn-Sondek, whose basic design has not changed in all these years.

So, do all of the high-tech phase-locked-loops, super servos, and LED readouts improve the quality of the music coming from the turntable? If I may answer my own question: yes and no. Some of today's super-fancy turntables are improved by hi-tech design, and some are not. This leads me to two conclusions: technology is wonderful, and, we cannot be assured that more technically complex designs will always yield more musical results.

To finish my short digression on the Linn PMS system, all of its components have been designed with musical output as the only criterion. I am convinced that it represents both an incredibly enjoyable home listening system, as well as an amazing diagnostic tool in the analysis of recorded music (and in the design and evolution of audio circuits, I might add).

THE FAULT LIES IN THE TURNTABLE

In those years between my Dynaco/AR system and the present tri-amplified Linn/Naim system, I have discovered that records are not as bad as both the public and the pro-audio community make them out to be. In fact, while record manufacturing certainly has its problems, the major problem is turntable design. Records played back on the Linn turntable (as well as a few others) are simply amazing. Those of you who can't stand to listen to your old records will be pleasantly surprised at the amount of musical information and enjoyment that lurks in those old grooves. (In fact, a large amount of 10-20-year-old records sound as good or better than today's records.) However, the bulk of the turntables on the market today are just not up to the task of playing back records. The manufacturers keep adding features while lowering prices, without much regard to extracting the musical information stored on the record. (Just a note: surprisingly, as a turntable's "musical" design improves, the amount of disc surface noise decreases.)

A NEW CONTENDER

And now, enter the Compact Disc. The promise is wonderful. Huge dynamic range due to "no" noise; convenience of use; a relatively non-destructible medium. Finally, the true performance of digital can be realized. It is interesting that those of us who have criticized the sound of "digital" recordings have been told that the problem is that the analog record cannot handle the full dynamic range afforded by the digital master tape. This is what causes the bad sound. When the Compact Disc arrives (or so we are told), we will finally hear the "real," the wonderful, the magic of digital.

Of course, we were also told that recording engineers have been "engineering for analog" all of these years. They will now have to re-learn their trade. After all, the reason that digital recordings sound bad is that they were engineered with analog in mind. Is this true? Well, since analog records cannot let through what the Compact Disc promises, we will only find out when the Compact Disc reaches the marketplace.

Well...listen up. The Compact Disc is here. As stated above, the design objectives are admirable and well-defined. All of us in the music and related equipment and service business look forward to the emergence of a system that will

Michael Tapes is the president of Sound Workshop Professional Audio Products, Inc.

excite the public to the point where the purchase of recorded music will once again be important in their lives. A medium that will encourage purchase rather than copying is also vital to our survival.

And, if the promise of sonic performance is proven correct, we shall all benefit—as listeners, with more enjoyable music in our homes, as engineers, with a better vehicle for our science and art.

However, the public may not jump at the technology all that quickly, especially after being severely burned with the promotion of quad. What is needed is a viable product that will deliver long-term satisfaction and value. Let's examine whether the Compact Disc will do this.

In investigating both the Compact Disc and peoples' attitudes toward it, I have found three prevailing attitudes:

1. It is amazing. It answers all of our needs. It is musically and technically "perfect."
2. It is musically unpure. The technology is not proven. It is a total waste and much too early for introduction.
3. It is very exciting and important, but its musicality and reliability (over time) is uncertain.

Let's move ahead—but slowly.

THE INVESTIGATION

I must confess that I entered this investigation with attitude number three. My earliest experience with digital records was simply that they sounded a lot worse than analog records. However, I took on this assignment with an open mind—along with a Technics model SL-P10 Compact Disc Player.

I went to my local record store and purchased several discs. It was important to me that the material on the discs was familiar and analog (if we can have "digital" LP records, I guess that we can have "analog" Compact Discs). In this way I could better isolate the "effect" of the Compact Disc system. Yes, at that point I expected a CD "effect." By using familiar material I also planned to compare the discs to my existing LP records. Since I listen mostly to pop music, my purchases reflected this. Also, I could not find much (if any) classical music that was originally recorded analog.

This purchase of "analog" material goes against the promoters of CD. They tend to say that analog material will not show off the benefits of CD, that one must have a pure digital master in order to really enjoy CD. Well, I didn't want to enjoy CD, I wanted to enjoy music. And so I proceeded (although I did purchase some digitally recorded CDs as well).

The Technics player is high-tech, well built, and professional. A button is pushed and a motorized magic door pivots toward you. I inserted a disc and the door smoothly retracted, sucking the disc inside. It was all very seductive, and I was into it. My first disc was Simon and Garfunkel's *Bridge Over Troubled Water*. (The salesperson at the store said I shouldn't buy it because it was not a digital recording and there was a lot of hiss on it.)

I pressed #6 followed by PLAY. Some fluorescent readouts changed their status and moments later my analog duo were singing the strains of "The Only Living Boy in New York." I was in awe of the sound. Unbelievable. No ticks, no pops, no clicks. Just S&G. Yes, there was hiss, but it was constant and unobtrusive, and not very loud at that. I skipped around the disc (it's very easy to do) and finally I decided to do an A/B to the LP record.

It was no contest; the record lost. Even though I am extremely careful with my records, poor Paul and Art were being rudely interrupted with all kinds of noise on the record, while being bathed in glorious silence on the Disc. I was converted. But now, my anti-digital bias would have to be re-directed towards the bad digital recording techniques of the engineers. Obviously, if CD players sounded great, the professional digital multitracks and mastering machines must be OK, too.

First impression: I had been wrong about digital all along.

All that I had come to believe was down the drain, due to the overwhelming seductive silence and convenience of the Compact Disc.

Well, several weeks have gone by. While the "new toy" aspect of the CD still exists, I have gotten over the thrill of first impressions. I have had many people to my home to listen and evaluate the CDs. I even acquired two other players to confirm or contradict the performance of the Technics. My impressions based on my experiences and the observation of others are as follows.

IMPRESSIONS OF THE HARDWARE

The CD "system" is in its infancy. All three players sounded different (contrary to the mass circulated magazine reviews). One can come to drastically different conclusions depending on which machine is auditioned. Since I had only one sample of each machine, I could not determine if these were sample-to-sample deviations or if the differences were based on the differing designs. Yes, contrary to the promotion that all of the players are the same, they go about decoding the discs differently. Some of the differences are: number of laser beams, number of D/A converters (some multiplex for left and right channels), sampling rate, filtering techniques, and so on.

The best of my players was the Technics, and that was the machine that I listened to except when comparing machines. I might add that the differences between machines were not linear. That is to say that machine A might sound better than machine B on loud passages, but B might sound better than A on low level passages. In addition, and much to my surprise, the machines also varied in their reproduction of dynamics. That is to say that each machine not only sounded different, but they also were not dynamically linear. This aspect was a complete surprise.

One of the anticipated virtues of CD is the elimination of the problems associated with the choice of cartridge/arm/turntable combinations and their proper setup. Well, based on the variations in the three players used, we still have a long way to go. My conclusions regarding the first generation hardware is that there seems to be no way to determine the best player or to know if it is indeed working properly. The magazine reviewers are merely playing test Discs and measuring numbers. Their conclusions are that the machines spec out better than analog and that they all sound great. WRONG!

LOOK MA, NO NOISE

It is an amazing experience to listen to music without the associated record noise we have come to tolerate. From a musical and artistic point of view, there is much to be said for the elimination of this garbage that is always added without the consent of the composer, artist or producer.

This elimination of noise reveals itself in an extended dynamic range that is clearly desirable in the listening experience. It is reminiscent of the days when Dolby A Noise Reduction was first introduced. However, it was incredible that we had to deal with the psychoacoustic phenomenon of no noise. At first hearing, this tends to make the material sound dull and rolled off. This also happens with the CD. The music sometimes sounds dry and disjointed due to the lack of noise. To some this is a thrill; to others it is unnerving. Have we been listening to "noise-biased" music for so long that when provided with a noise-free alternative it sounds wrong? Or does CD have its own set of problems that tend to make the music sound unnatural? I say YES...to both.

If we look at professional audio engineers, we see that many of them are not using noise reduction as often as before, having mostly decided that the benefits of Dolby and dbx are more than offset by audible side effects.

This no doubt will be repeated with the CD experience. Almost everyone will be knocked over by the lack of noise and the convenience of operation, and many may temporarily ignore any sonic side effects of the digital process. Also—and

not yet fully addressed—is the question of implementing precision technology in a mass-produced box that is targeted for the lowest possible cost.

THE MUSIC PROBLEM

If we can separate ourselves from the luxury of a relatively noise-free source, we will see that the music (remember that?) truly suffers in the CD environment. Music loses its ability to compel the listener. What is reproduced is a series of noises that our brain translates into what we know should be music. No one would argue that listening to a \$50 phonograph is awful, yet the brain can still translate the noise into music. It's not necessarily a satisfying musical experience, but we still know that that distorted mess is music. CD yields high-fidelity noise compared to the \$50 special, but it is the conclusion of myself and many others that the critical information that makes the high-fidelity noise into a satisfying musical experience has been stripped away by digital and specifically by the CD process.

Many will disagree and will have satisfying musical experiences with CD, at least in the short run. For many, CD will be such a step up from inadequate (but maybe expensive) turntables that they will be thrilled beyond their wildest dreams, not realizing that a properly designed turntable would probably be even more satisfying in the long run.

There can be no dispute that records have a tremendous potential for damage over time. The CD has much less of a chance for damage. On several occasions in my usage a seemingly trivial fingerprint has affected the CD playback. On one occasion a fingerprinted disc coughed, clicked, popped and muted in one machine, wouldn't even begin to play in another machine, while in the third it played, seemingly unaware of the presence of the print. When wiped off, the CD played properly in all three machines. Assuming

the musical content is indeed on the disc, the CD (even at its \$20 price) seems like a good longterm investment in terms of the physical medium. If indeed the musical content is not intact, then we have purchased archival noise.

IN CONCLUSION

So what's a mother to do???

For me, it's wait and see. I would love to see the CD come into its own and provide the full spectrum that it promises to offer. It is not here today. Should one run out and buy a CD player? It depends. Those of us who are techno-freaks and want to know and learn the truth about new technologies firsthand should buy one. Those who want the convenience and silence that the CD offers should buy one. Those music listeners who only want the best possible musical reproduction in their homes will not be satisfied with today's CD.

And what of the engineering community? Have we all the while been putting out bad sound product that is now discovered to be unacceptable in the digital domain? Sure we have...but we have also put out great-sounding music. Do we need to review our recording techniques? Of course we do. But competent artists in all fields of endeavor stop and review every so often. If CD and the digital recording processes force us to examine whether other parts of the recording chain (consoles included!) are up to their musical limits, then great. But let us not look over the newest technologies (digital) and think that they are unerring due to their fresh and seductive virtues. Let us evaluate the entire recording and listening chain.

I for one will continue to research and evaluate CD, because if we can overcome its problems it will benefit us all—both artistically and financially.

Now if you will excuse me, it's time for the yearly replacement of my stylus. ■

Do You Know Where?

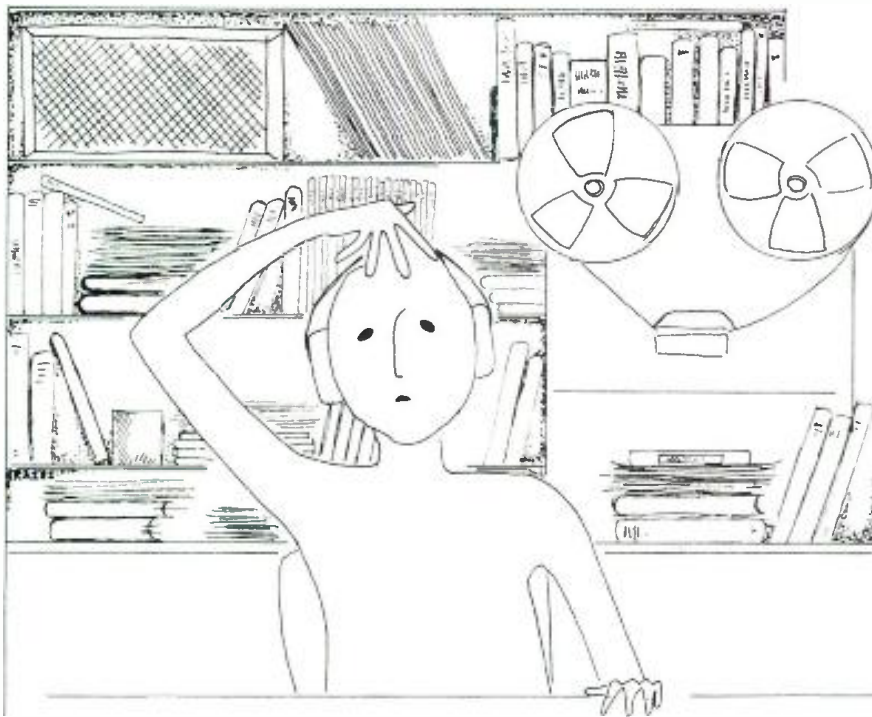

Have you misplaced your db again? Our high quality, royal blue vinyl binders keep 12 copies of db neat and handy for ready reference.

Just \$9.95, available in North America only. (Payable in U.S. currency drawn on U.S. banks.) ORDER YOURS NOW!!

Sagamore Publishing Co., Inc.

1120 Old Country Road
Plainview, NY 11803

YES! Please send _____ db binders @ \$9.95 each, plus applicable sales tax. Total amount enclosed \$ _____

Name _____

Company _____

Address _____

City _____

State/Zip _____

PRESIDENTS MESSAGE

"THE PULSE QUICKENS"

Mack Emerman



SPARS at this time is broadening its horizons as never before. Our membership continues to grow, which is most rewarding. The course we must logically follow becomes more apparent.

The video post production "familiarization" seminar which was held in Chicago on Saturday, August 5, was most enlightening to all participants, thanks to the generosity of Editel and SPARS Vice President Len Pearlman.

At our meeting in Chicago, the SPARS Board of Directors made the decision to realign our administration to better serve the organization for the many ambitious programs that are about to be undertaken.

I am pleased to announce that Gary Helmers, who has done such an admirable job as West Coast Coordinator, has been given the job of Executive Director of our organization starting November 1, 1983.

David Teig's position as New York Coordinator will stay as is, and well it should in recognition of the mighty contribution that Dave continually makes. We couldn't do it without you, Dave.

Nick Colleran will remain our Treasurer and Dannie Emerman will assume the position of "Corporate Secretary".

Our committee reports during the board meeting point to putting into place the "SPARS EXAM" by January 1984, as well as many other innovative programs soon to be announced.

On Monday, October 10 in New York, SPARS will interface with the Audio Engineering Society to sponsor a workshop on "The Business of Studios."

Our general membership meeting and installation of new officers will be coincident with the SMPTE Convention in Los Angeles the first week in November.

The nominating committee has posted the names of those nominated for officers and board of directors for the 1983-84 fiscal year. They can be found on another page of *Data Track*. I would like to congratulate the committee for their careful consideration of the many choices. I am personally most pleased with the slate as presented. There are old names, new names, old blood, new blood . . . a super combination that I know will do a great job next year. They will make my tenure as chairman of the board even more exciting than my year as president, which I can't believe is almost over.

A special thanks to *db Magazine* for printing this issue of *Data Track* as part of their AES issue. We appreciate the support of *db Magazine* and the valuable assistance and counsel of editor John Woram.

I would like to take this opportunity to thank the Board of Directors and Past Presidents who have worked so closely with me, for their unfailing support. I will look forward to being as actively involved as possible in the coming years, because as I'm sure you know, I believe in this organization and that it will continue to educate and bring together the many diverse elements of our ever growing and changing industry.

THE TRUTH BEHIND THE BLUE SKY HEADLINES

By Ruth A. Robinson
Music Editor
The Hollywood Reporter

As early as the end of 1982, reports began to be circulated and end up in print that the music business was about to jump back on its rocket ride to moneyland.

Of course, that was about the same time that the propaganda mills were churning out the news that the country's economy was back at full tilt. The hard reality is that neither the country nor the music industry is fully recovered, although our business is looking up.

But certain moves need to be made to ensure its continued growth, even if it is not a rocket ride. The records that are selling now were recorded a while back. Often they were cut at reduced rates in recording studios hungry for any business at all, when poised on the brink of bankruptcy or oblivion. Many, many studio owners are nervous.

The labels need to sign new acts . . . aggressively and not rely on inventories. Those new signings filter down to the service industries . . . the recording studios and instrument rentals . . . they create some excitement at the radio levels and give the consumer something new to bend their ears to.

Companies need to adopt a truly positive stance on the Compact Disc . . . all those who hesitate might end up with vinyl on your faces.

I don't know what happened to tour support from labels. It seems strange to me still to see a camera company sinking millions into Barry Manilow's tours or the beer company ringing up dollars from Men at Work concerts.

I'm enjoying listening to the radio again after a while of being bored to

continued next page

BLUE SKY continued from previous page
tears. On the other hand, if there were more deals cut, more music out there, there'd be even more to get happy over and it just might put some grins on the faces of recording studio owners and

instrumental rental companies . . . maybe even some limousine companies. Heaven forbid that we ever get prosperous enough that people start sending me T-shirts and pins and buttons and posters and satin jackets . . .

TO ALL SPARS MEMBERS **BOARD OF DIRECTORS NOMINATIONS 1983-84**



JERRY BARNES—PRESIDENT

Since 1972 Jerry Barnes has been Vice President of Recording for United Recording Corporation (a div. of Harman International) and General Manager of United/Western Studios in Hollywood CA. He has also served two terms as regional Vice President of SPARS and sits on its board of directors.

Jerry Barnes' career in audio recording covers a span of thirty years. His introduction to "making records" came when he and a group of high school buddies pooled their resources and purchased a primitive disc recording system. Barnes recalls that the device was portable and he and his friends utilized a neighbor's hay loft as their recording studio. "Since we didn't know better, the loft was as good a place as any to begin our assault upon the outside world. The main problem was to avoid stepping in anything soft on the way to the hay loft and now that I think about it, not much has changed. . . I'm still in this business because I don't know any better and I'm still trying to keep from 'stepping in anything soft'."

The early fascination with sound recording grew into pre-occupation during undergraduate days at Baylor University and in the years following. "I was one

of the early recording artists for WORD records and naturally I wanted my albums to sound as good as the ones being made by the superstars of the day. It seemed to me most of the really great sounding records were being made in Chicago and engineered by a guy named Bill Putnam at his studio called Universal.

No one in the south could come close to getting as much sound on a disc as Putnam so . . . my goal became fixed. I wanted to record an album in Chicago with Bill Putnam. After a year or two, I finally arrived there only to find that Putnam had departed for the West Coast so I was stuck with a young unknown mixer with a funny name . . . Bruce Swedien. He told me that he was a protege of Putnam so I gave him a shot. Bruce did good. I think he is still around. After observing how easy Bruce made it look I couldn't resist following the desire to make a career change and move to the other side of the glass. With role models like Putnam and Swedien I set out on the course that led me to where I am today. Happily, Swedien is a great friend and Bill Putnam, after having been my mentor for nearly fifteen years, is closer than a brother."

Today Jerry Barnes is a respected leader in the recording studio industry, a successful audio engineer, a published author and a speaker much in demand by academic and service institutions throughout the country.

C. NICHOLAS COLLERAN, JR. SECRETARY TREASURER

Nick Colleran founded Alpha Audio of Richmond, Virginia in 1971. He brought to Alpha Audio his experience as a CPA (B.S. in Commerce from the University of Virginia and work experience with



A.M. Pullen & Co.) and as an artist, writer and producer signed with CBS Records. At Alpha he has engineered for almost all the major record labels and has produced for several.

Today Nick is involved full time with the management of Alpha Audio (five recording studios); a full time in-house jingle and scoring production company (Candyapple); a professional audio sales and service company; and nationwide distribution of acoustic materials from warehouses in Richmond and Minneapolis.

Recent projects include: from the studio — *Snuff* on Warner Brothers Records (#93 with a bullet, 8/15); at Candyapple — production of a live stage show for Reynolds Metals; the audio equipment company — Richmond Symphony Concert Hall; and acoustic materials going everywhere!

Mr. Colleran has served on the Board of Directors of SPARS for 3 years as a regional Vice President and Treasurer.



**BOB LIFTIN
VICE PRESIDENT—EASTERN**

Bob Liftin's success in the audio industry stems from a unique and sensitive ability to read the tides of the future with an unquenchable thirst for knowledge and a constant driving desire for advancement. Today, owner/president of Regent Sound Studios, New York, Bob Liftin believes we have entered the most rapidly

DATA TRACK is published by
The Society of Professional Audio Recording Studios.
Editor: Gary Helmers

Please send all news and comments to Editor, SPARS, P.O. Box 11333, Beverly Hills, CA 90213

advancing and most challenging times for electronic innovation, and computer controlled accuracy and speed as well as a new era in the presentation of entertainment. The audio medium is by-passing its former limitations of dynamic range, reproductive quality and transmission ability. The linking together of the audio and visual experience will lead to new levels of artistic expression.

Beginning at the age of seventeen he was an assistant engineer and maintenance technician at Allegro Sound Studios, New York. At eighteen while still attending the City College of New York with a major in physics, he worked for CBS where he gained his experience in live broadcasting as a maintenance technician. In 1958 at the age of twenty-one Bob Liftin opened Regent Sound Studios recording, mixing and mastering records. In 1973 Regent Sound Studios pioneered the synchronization of two multitrack audio machines. By 1975 video was added and complete electronic editing and synchronization of film, video and audio in all formats was achieved by 1979. Presently a four studio recording and audio post-production facility, Regent Sound Studios services the record, advertising, television broadcast and film industries.

Bob Liftin spends an average of 10 hours per day behind the console as a recording and mixing engineer as well as maintaining an active schedule doing location recording and post-production on a variety of T.V. music specials. He is Audio Consultant for "Saturday Night Live" and has held that position for eight years. Bob is also chief audio consultant and main line mixer for the MDA labor day telethon; as well as The Tony Awards.

CHARLES M. BENANTY
VICE-PRESIDENT—EASTERN

Charles M. Benanty established Sound Works Digital Audio/Video Studios in New York in 1978. Mr. Benanty was a founding member of SPARS and has served on the Board of Directors as Eastern Vice-President for one year.

LEN PEARLMAN
VICE PRESIDENT—CENTRAL

Lenard Pearlman is currently Vice President of Technical Services for Editel-Chicago. Over the past ten years Len has held both engineering and management positions. He has been responsible for not only the technical direction, but the design and construction of the Chicago facilities

continued next page

EXCELLENCE THROUGH INNOVATION!

The SPARS regional meetings examine a variety of topics of interest and value to the audio recording industry. The topics range from immediate maintenance problems to future concerns, such as the role audio recording studios will play in interactive video. Through teleconferencing,

any studio in the country can participate in these meetings. Participation is increasing constantly and we welcome all inquiries regarding involvement in the regional meetings.

For further information, contact any SPARS office.

EXCELLENCE THROUGH EDUCATION!

The SPARS thrust into the field of education is moving forward on several levels. Our interfaces with students at the University of Miami and the University of Colorado at Denver were productive and beneficial for the students and also the professionals that participated.

SPARS has initiated a pilot program to provide internship experience for students in the audio engineering field. Students have been grateful for the exposure to the real world of the recording industry and the studios value these initial contacts with the individuals who will be their employees of the future.

Larry Boden, of the JVC Cutting Center, is progressing rapidly with the development of the SPARS Certification Exam. This test will provide a common denominator for evaluating potential

employees from a variety of educational and experiential backgrounds. Any input that professionals in the field of audio engineering can provide is solicited. Write five multiple choice questions today and send them to any SPARS office! We'll see that they get to Larry.

The Digital Education Program is our educational thrust on the consumer level. We are concerned that the acceptance of digital technology might be impeded by a lack of understanding by the consumer. The transition to digital technology will require an unprecedented amount of cooperation within our industry. The Society of Professional Audio Recording Studios is working to insure cooperation between record labels, hardware manufacturers, software producers and record retailers.

EXCELLENCE THROUGH COMMUNICATION!

Thanks to *db Magazine*, *Pro Sound News*, *Mix Magazine* and *REP* for their assistance in presenting the DataLine program to the audio recording industry. The letter below is but one example of the gratifying response we have received. At some time, some place, someone in SPARS has faced the problem you may be facing today. Let us help!

April 25, 1983

Dear SPARS,

When Bob and I saw the announcement for the new DataLine, it appeared at a time we needed some information about the business operations of recording studios. With one phone call to DataLine we quickly received answers or options for all of our questions. These answers, we are convinced, have saved us

from making costly mistakes and will add to the income of our studio.

Please extend our sincere appreciation to SPARS for providing this service. Thank you for your time, courtesy and genuine willingness to help.

Yours,
Mary Curlee
Business Manager
Strawberry Jamm
West Columbia, South Carolina

Questions regarding any area of recording studio operations including business, audio engineering and technical maintenance will be answered by SPARS-approved sources at no charge.

Want a problem solved? . . . call SPARS
—(305) 443-0686.

as well. Prior to Editel, Len held production positions for both ABC and PBS affiliates, and worked in the Chicago Recording Industry. He has recently been elected as a manager of the Chicago chapter of the SMPTE.



JOHNNY ROSEN
VICE PRESIDENT-CENTRAL

Johnny Rosen is the president of Fanta Professional Services, Nashville, Tenn., which specializes in mobile recording for the entertainment industry. Fanta's clients include all four major television networks, several major film companies, radio networks and syndicators, and most major record labels. Mr. Rosen has received film credits for his work on Robert Altman's "Nashville", "Coal Miner's Daughter", and "The Blues Brothers". Additional credits include approximately 250 audio projects such as audio/video fusions for the opera "A Bayou Legend" for the Public Broadcasting Service. Mr. Rosen's consulting projects have included noise control in industrial situations, numerous recording studio specifications, and work for the White House Communications Corps. Mr. Rosen attended Rollins College in Winter Park, Florida where he concentrated in English and electronic media. He is currently an adjunct professor of music at the Blair School of Music at Vanderbilt University and has been a guest lecturer at several universities in the United States. Actively involved in the Audio Engineering Society since 1968, he has been committeeman, chairman, treasurer of the Nashville section and is now serving on the board of governors of A.E.S. as the central region vice-president. Mr. Rosen has presented papers at A.E.S. conventions dealing with new approaches to motion picture sound and has written articles for *Studio Sound* and *Pro Sound News*. He has lectured at the national meeting of SPARS. Currently, Johnny is the Nashville Vice-President of SPARS. He is also a member of the National Academy of Recording Arts and

"GRAMMY" RECOGNITION FOR STUDIO PARTICIPATION

The National Trustees of NARAS (National Academy of Recording Arts & Sciences) have voted to create a plaque or similar form of acknowledgement to recording studios who have participated on Grammy-winning recordings. The participation-confirmation will indicate the title, artist and category of the Grammy-winning recording, along with the name of

the studio. As soon as details have been finalized the plaques will be available to all eligible studios at a cost to be determined.

SPARS Past President and NARAS National Trustee Murray Allen, was instrumental in the creation of this acknowledgment of studio participation on Grammy-winning recordings.

BRUCE BOTNICK VICE PRESIDENT - EASTERN

Bruce Botnick began his career in audio at Liberty Records Recording Studios as an engineer. His projects in the early 60's included: The Chipmunks, Bobby Vee, The Fleetwoods, The Ventures, Jan & Dean, Jackie DeShannon and Leon Russell.

From Liberty Records, he moved to Sunset Sound Recorders in 1963 to continue as an engineer and adding the roles of producer and studio manager. Bruce's projects at Sunset included such diverse talents as Love, The Doors, Randy Newman, Marvin Gaye, Claudine Longet and Little Stevie Wonder.

In 1968, Mr. Botnick began a three year tenure with Elektra Records as engineer, producer and studio manager. His client list grew to include: The Rolling Stones, Dave Mason, Delaney & Bonnie, Judy Collins, Janis Joplin, Santana and many others.

After becoming an independent engineer, Botnick won a Grammy Award in 1972 for "Best Spoken Word Recording" as the producer of "Lenny," the first Broadway play recorded live on stage. The list of artists continued to grow - Helen Reddy, Mac Davis and Earth, Wind and Fire. 1975 brought a contract as Executive Producer with CBS Records and more artists-Les Dudek, Jerry Goldsmith, Eddie Money, Kenny Loggins and production of the soundtrack LP for Star Trek. In 1981 Bruce produced the Grammy Award winning recording ("Best Male Pop Vocal") of Kenny Loggins "This Is It" from the "Alive" LP.

Today Mr. Botnick is an independent engineer for Bruce Botnick Productions, Inc. and President of Digital Magnetics, Inc. Recent projects include production of the music for "Twilight Zone." "Under Fire" (an Orion film to be released September, music featuring Pat Metheny) and the new Sean Connery-James Bond feature "Never Say Never."

Sciences, the Country Music Association, and is an elected board member of the Nashville Music Association serving as chairman of the studio division. Also, Mr. Rosen is serving his second three year term on the board of the Nashville Symphony. Notable recording projects range from the Rolling Stones to the Philadelphia Symphony Orchestra.



LARRY BODEN
VICE PRESIDENT-WESTERN

Larry Boden is a native of Pittsburgh, Penn. He received a Bachelor of Fine Arts degree from the Conservatory of Music at the University of Cincinnati in 1969. He is currently chief engineer of the JVC Cutting Center in Hollywood, Calif., and has been in that position since early 1980. He has been employed previously by MCA Records in Los Angeles; National Record Productions, Nashville; and Rite Records in Cincinnati. As a mastering engineer, some of his credits include Crystal Gayle "Don't It Make My Brown Eyes Blue," Don Williams, The Who, Grandfunk Railroad, soundtracks from many movies including "Smokey and the Bandit", "American Graffiti" and others. He is an active writer on both disc mastering and digital subjects. His articles have appeared in *The Mix*, *International Musician*, and *Recording World* and other publications.

ANALOG SHOOT-OUT - DUEL OF THE 24'S

by Ken Easton

Saturday, August 6, was another in a series of hot and muggy days that Chicago has suffered through this summer. It was also the last day of the SPARS board meeting. Things had gone well and the various board members felt it had been well worth the trip and time.

As the day moved toward the late afternoon, everyone began to feel a little anticipation for the last event of the meeting—the “Analog Shoot-Out—Duel of the 24s,” as it was billed on the SPARS agenda. As Joe Tarsia of Sigma Sound in Philadelphia recalled, “Being in the market for multi-track machines, I was excited about it. I’m always interested in what’s available, and being able to hear these two machines, side by side, in direct comparison . . . it was a real opportunity.”

The two machines Joe was referencing were the Studer A-800 and the Otari MTR-90-11, both 24-track analog recorders. A major difference between these two machines, even to the untrained eye and

ear, or the nontechnical mind, is about \$25,000—the Studer selling for around \$65,000 and the Otario for close to \$40,000. So there was reason for interest in the shoot-out.

It was decided early that the OK Corral would not be an appropriate location for the shoot-out. It was also decided that Studio A of Murray Allen’s Universal Recording would be quite appropriate. Rich Breen, Technical Manager at Universal and Chief Engineer for the shoot-out, and several others put a good deal of effort, time and energy into the preparation of the event. “Danny Leake, who was the recording engineer for this, and I started working on the machines about eight o’clock that morning,” Rich Breen remembers. “We wanted to have everything ready well ahead of everyone’s arrival.

“Both machines were biased . . . everything was set up to be as flat as possible, according to the tape machine manufacturers’ recommendations, as far as eq and that sort of thing,” Breen continued. “There were two other machines in the

booth besides the Studer and the Otari, an MCI and a 3M digital 32-track. We also prepped them, even though they weren’t a part of the shoot-out. They were more for control.

“So, all machines were biased and set up pretty carefully. Reps from both Studer and Otari were there to make sure everything was done properly . . . to check it all out. In addition, we went through the console to check for flatness and source; all that kind of stuff. We wanted to make sure it was just right. Then when he fed the machines, Danny came off the same busses. That way we had eight tracks, to each machine that were the same. Also, he fed to the center eight tracks, to avoid edge-tracking problems. Everything was done that was humanly possible to make those machines as equal as could be. Basically, we wanted to be as fair as we could.”

It got to be close to 4:00 p.m. and people started arriving. SPARS people, other industry people, a few musicians . . . all with a common interest—the Otari/Studer shoot-out. And they all wanted to fit into the booth of Studio A! In the recording studio itself, the musicians of the rhythm section (Bruce Gaitsch, guitar; Bob Livzick, bass; Pat Leonard, keyboard; and Jim Hines, drums) had long since assembled, set up, and were busy rehearsing for the tracks they were soon to lay down. These really fine studio musicians provided an extra measure of excitement to the whole event.

Rich Breen described the recording and playback procedure. “When Danny laid the tracks, he was listening to the busses, so that when the tracks came back, he could just put his faders up in a straight line and listen to them. In other words, playback could be done with eight faders in a straight line. Then what we did, on playback, we just brought the two machines back on two groups of eight faders, which had been checked ahead of time with an oscillator, to make certain that all levels were identical. Once again, just trying to be sure that everything was equal, and it was!

“We then bussed out to two listening busses, which we could switch between quickly, with identical electronics. They were A/B’d. This allowed us, on playback, to run the machines together and quickly switch back and forth for comparison. First, we recorded a rock ‘n’ roll track with lots of guitar and drums, and then we did a solo piano track. And that was about it. From there, it was a matter of listening to playback.” *continued next page*

SPECIAL INSURANCE PROGRAM DEVELOPED FOR PROSOUND INDUSTRY

At a luncheon meeting of White Plains Insurance Underwriters, Henri van Dam, Vice President of A. Matarasso & Co. in White Plains, New York, discussed a comprehensive insurance package he has specially tailored to address the unique needs of the Sound and Video studio. Highlights of this unusual program include provisions which cover the loss of recorded tapes in the event they are stolen or destroyed. Distinguished from conventional recording studio policies, van Dam’s package offers bailee coverage for recorded material. To those in the industry with first hand knowledge of the costs involved in producing tapes, van Dam remarked that the advantage to having this specific coverage was obvious.

He went on to explain that another feature of this carefully designed and well thought out offering is coverage for equipment that is insured on a replacement basis. Furthermore, he explained to those present, if the equipment is not worth replacing because it is outmoded by more modern technology, coverage can

be written to pay for upgraded equipment.

Van Dam noted that conventional comprehensive policies generally provide protection against serious property damage caused by catastrophic events such as fire, flood, and theft. However, he continued, recording studios require additional protection against loss of income which occurs when studios become untenable causing recording activities to cease. Van Dam is writing Business Interruption Insurance that is specially designed for sound studios which covers the net profit continuing expenses, and salaries which would have been earned had there been no interruption in business activity.

Van Dam stressed the fact that his special insurance program fits the needs and distinctive peculiarities of the sound industry. Among his clients are such leading studios in the Greater Metropolitan and lower Connecticut area as A&R Recording, Power Station, Minot Sound, P&P Studios, Skyline, Squires, and Media Sound.



STUDIO TRACKS SOUNDSHOP RECORDING STUDIOS

NASHVILLE

Producer Ron Chancey was in working on some McDonald's commercials with Les Ladd engineering.

The Jimmy Sturr Polka Band were in cutting their new album. Tom Pick engineered.

RCA artist Leon Everette cut his latest with producer Ronnie Dean. Mike Bradley at the board.

Buddy Killen was in producing Ronnie McDowell for CBS. Ernie Winfrey behind the board.

Larry Gatlin & the Gatlin Brothers worked on a project with Larry Gatlin producing. Stan Dacus and Mike Bradley engineered.

Sawyer Brown worked on a few sides with J.C. Meyer producing along with Mike Bradley. Bradley also engineered.

Val & Bertie did some song demos with Travis Turk engineering.

CBS artist Chet Atkins did string overdubs with Ernie Winfrey engineering.

BBD & O, Detroit, came to Nashville to work on a national campaign jingle for Dodge. Producing was Craig Deitschmann. Mike Bradley engineered.

Artist Leon Raines was in with producers Milton Brown and Steve Dorff. Travis Turk engineered.

CRITERIA RECORDING STUDIOS

MIAMI

Recording their sixth album at Criteria Recording Studios in Miami is Firefall on Atlantic Records. Producing the album in Criteria's Studio E are Ron and Howard Albert of Fat Albert Productions. Patrice Carroll Levinsohn is the assistant engineer.

Out of the Criteria Cutting Center comes *Hey*, the second single release from the album *Julio*, by international recording star, Julio Iglesias. Mike Fuller mastered the disc which appears on CBS International Records.

Mixing is being completed on a "live" double album by Julio Iglesias at Criteria Recording Studios in Miami. Producer Ramon Arcusa is working on shows taped in Paris, Tokyo and London. Bob Castle is engineering. The album will be released on CBS International Records.

A new arrival to Criteria's East Wing studio is artist Mink de Ville on Atlantic Records. Producing the album are Ron and Howard Albert of Fat Albert Productions. Patrice Carroll Levinsohn is the engineering assistant.

Please include SPARS on your press list!

we solo-out so we can really test everything?" And on it went.

And what were the results, if any? As Rich Breen put it, "My impression was that the two machines were extremely close. The only difference, and this wasn't a big surprise, was in the low end. The Otari starts to roll off about 10 Hz above where the Studer begins to roll off. What was surprising was that there was virtually no difference in noise between the two. I didn't hear any strange modulation noise on either the Otari or the Studer. Whatever the differences, and I'm not sure you'd notice any of them outside of an A/B situation, whichever machine is best is a matter of choice. I'd be real hard pressed to pick a winner."

The keyboard player on the session, Pat Leonard, was a little more inclined toward one side. He commented, "I really like what the Otario did in the midrange of the piano. It seemed to open it up and gave it warmth. I'm not saying that it changed the piano sound. The Otari just made the piano sound more like how I think a piano should sound. It's funny, all my career it's been Studer. Now, I'm hearing some competition." Drummer Jim Hines was standing by and added, "Tone doesn't mean that much to me. My ears aren't trained for that. Me . . . I hear the highs and lows. For what it's worth, I really couldn't tell the difference between the two machines."

But what were the thoughts of some of the SPARS people present? Once again, Joe Tarsia of Sigma Sound: "I think that the real success of the shoot-out was that it was demonstrated that the companies who are producing professional audio machines are doing such a good job that we *did* have a very difficult time hearing any difference. On the other hand, had I been running the test, I would have wanted to compare each machine to the live performance, also. I just think it would have been better to compare the input to the machines (the live performance) to the output (A/B). That way you're comparing each machine to the original sound. If one machine sounds brighter, or fatter, it might not be fair to say it sounds better, if it doesn't sound like the original."

Tarsia continued, "A shoot-out like this one leaves a lot of questions unanswered. Now, I realize that this shoot-out was intended only to test audio performance. I think it would be a mistake to say one machine is a winner and the other's a loser. You have to consider other things like overall performance, reliability, durability, and many more factors. While it was very difficult to tell a difference between the two machines, I don't think anyone should buy an expensive piece of

SHOOT OUT *continued from previous page*



SPARS President Mac Emerman, President Emeritus Joseph Tarsia and Eastern Coordinator David Teig listen for a difference.

And playback they did, for at least an hour-and-a-half. Over and over, they A/B'd dozens of times. Different people wanted to hear different things. So, they would solo-out special tracks, like the kick and snare of the drum tracks, and they'd A/B that several times. Then someone would request to hear the solo piano once again, and heads would angle so that straining ears would have a better shot at the monitors. Among the 20-or-so people in the crowded booth, and the rest who spilled into the adjacent room, the hall and the studio itself, questions were being asked like, "Well, what do you think?" "Can you hear a difference?" "What else can

equipment because of the results of a shoot-out. You should be looking for a lot of answers, and if you're not getting the answers, ask the questions."

Mack Emerman of Miami's Criteria Studios had this to add, "The shoot-out was fun. It was interesting. People got certain impressions. There were a lot of variables that obviously came into play, and whatever we heard there really isn't the last word. I also wish we had been able to compare the A/B with the live source.

"We certainly had our impressions, but I don't think anyone in the SPARS organization would live or die by those impressions. There's a lot that goes into why you buy a tape machine. There are all sorts of

cases you can make for sound impressions. One person might hear smearing on one machine, another might feel the other machine is more open. To my ears the MCI sounded, almost imperceptibly, more open. Then someone else will come along who has no idea of what 'smearing' or 'open' means. The differences are so subtle that they are almost insignificant.

"Otari, Studer, MCI . . . these people make fine products, and I think you would see a wide variety in use across the SPARS community. We're all looking for something different. It's a matter of taste. We're all owners of service organizations and it's probably better for us to offer a diverse line of equipment to satisfy all of those different tastes."

And finally, Murray Allen of Chicago's Universal Recording was overheard to comment, "Obviously, we're all going to get asked a lot of questions about what went on here today. Everybody heard many different things in the room. It seems to me, in the final analysis, the choice of a tape recorder is pretty much personal opinion. That is, as to what sort of a sound you would like to hear. It's really personal choice."

*About the author—
Ken Easton is a free lance writer, and has been a professional musician for nearly 30 years. He is presently producing and directing an industrial film starring former football great Gale Sayers.*

ATTENTION STUDIO ADMINISTRATORS

SPARS wishes to remind you of the importance of having a voice in the audio recording industry as a member of the Society of Professional Audio Recording Studios. Becoming a member is simple, inexpensive and a good investment. Dues are attractively low – as little as \$1.00 a day – and the rewards of education and communication far exceed the dollars invested.

We invite you to attend our Hospitality Suite in the Warwick Hotel, during the AES convention, to discuss the concerns of our industry and how SPARS is addressing these concerns. If you desire more information regarding SPARS, circle #50 on the Reader Service Card. If you would like to become a member of SPARS, complete the membership application below and send it in today!

CIRCLE 50 ON THE READER SERVICE CARD

APPLICATION FOR MEMBERSHIP TO SPARS

NAME		TITLE	
COMPANY		PHONE	
ADDRESS	CITY	STATE	ZIP
<input type="checkbox"/> REGULAR MEMBERSHIP	\$365	Any professional recording, mixing or mastering facility with gross billings under \$1 million.	
<input type="checkbox"/> SUSTAINING MEMBERSHIP	\$1000	Any professional recording, mixing, or mastering facility with gross billings over \$1 million, or others grossing under \$1 million who wish to contribute to our growth.	
<input type="checkbox"/> ADVISORY MEMBERSHIP	\$2500	Includes any company presently engaged in providing services and/or supplies for the recording industry, not qualified for membership in any of the preceding categories.	
<input type="checkbox"/> ASSOCIATE MEMBERSHIP	\$250	Includes any company or individual presently engaged in or utilizing the services of the recording industry, not qualified for membership in any of the preceding categories.	

Accompanying this application is a check in the amount of \$ _____ covering membership dues for the fiscal year.

MAIL TO: SPARS, P.O. BOX 1060, COCONUT GROVE, FL 33133



SPARS NATIONAL REGIONAL UPDATE

NY UPDATE

A series of nine New York Regional luncheons have been scheduled for 1983-84, most of which will be held at Gallagher's Restaurant. The dates are: September 28, October 26, November 30, January 18, February 22, March 28, April 25, May 30 and June 27.

Bob Ludwig of Masterdisc will be the guest on September 28 and will explain in detail the preparation of a CD mastering tape and will present other manufacturing information about the Compact Disc.

On October 26, Henri van Dam of

A. Matarosso & Company will return to a SPARS luncheon and give studio owners an Employee Benefit Seminar dealing with IRA, Keogh, pensions, deferred compensation plans and employee agreements.

On November 30, interactive video will be explained and demonstrated by Frank Dobbins of Editel-Washington, D.C., an expert in the field. A discussion will be held regarding the role audio recording studios will play in this new technology.

Watch future *Data Track* issues for additional topics and guest speakers.

CHICAGO UPDATE

On Saturday, August 6, Editel-Chicago hosted a seminar for SPARS members on the videotape post-production process. Attending with the local SPARS member studios were members of the SPARS

Board of Directors and many of the manufacturers who serve as advisory members.

Pete Jannotta of Editel explained the film to tape process and demonstrated the latest trend of transferring the negative film elements on the Bosch Scanner. Computerized videotape editorial was demonstrated by Tom Evans, and the use of digital video effects to add electronic opticals were shown to the group. Scott Thomson showed examples of multi-track audio techniques for the improvement of audio for video on segments from the nationally syndicated show "Celebrity Showcase". Len Pearlman, Vice President of Technical Services for Editel, discussed the latest trends in post production and showed examples of some of Editel's recent projects. Sony's Beta-HiFi consumer VCR was also demonstrated along with its latest video music software. The seminar provided a forum for education and discussion as many common topics were discussed during the day's seminar.

SPARS Board of Directors
and Administrative Staff
(305) 443-0686

Chairman Emeritus
Joseph D. Tarsia
Sigma Sound Studios
Philadelphia

Ex-Officio
Murray R. Allen
Universal Recording Corporation
Chicago

Chairman of the Board
Christopher Stone
Record Plant, Inc.
Los Angeles

President
Mack Emerman
Criteria Recording
Miami

First Vice President
Guy Costa
Motown/Hitsville USA
Los Angeles

Vice President-Secretary
Leroy Friedman
Columbia Recording Studios
New York

Treasurer
Nick Collieran
Alpha Audio
Richmond

Regional Vice President
Jerry Barnes
United Western Studios
Los Angeles

Regional Vice President
Charles Benant
Soundworks Digital Audio/Video Studios
New York

Regional Vice President
Leonard Pearlman
Editel Chicago

Regional Vice President
John Rosen
Fanta Professional Studios
Nashville

Assistant to the President
& Eastern Coordinator
David Tsag
New York

Western Coordinator
Gary Helmers
Los Angeles

Technical Consultant &
Educational Committee Chairman
John Woram
Woram Audio Associates
New York

Administrative Director
Dannie Emerman
Miami

Public Relations
Bobbi Marcus
Los Angeles

Legal Counsel
Malcolm Pierce Rosenberg
Wolov & Rosenberg
Philadelphia



Give the gift
of music.

SPARS PROUDLY ANNOUNCES THE FOLLOWING NEW MEMBERS

REGULAR
THE PLANT
2200 Bridgeway
Sausalito, CA 94965
Contact: Paul Broucek

ASSOCIATE
ANTHONY AGNELLO
Eventide Clockworks, Inc.
265 West 54th Street
New York, NY 10019

RICHARD FACTOR
Eventide Clockworks, Inc.
265 West 54th Street
New York, NY 10019

VINCENT RUSSO
Eventide Clockworks, Inc.
265 West 54th Street
New York, NY 10019

DOUGLAS F. ORDON
AVC Systems Inc.
747 Church Rd. Suite A6
Elmhurst, IL 60126

**CLARIFICATION FROM
PREVIOUS ISSUE.**
**THE FOLLOWING ARE
REGULAR MEMBERS:**
STUDIO ONE, INC.
3864 Oakcliff Industrial Court
Doraville, GA 30340
Contact: Gloria Buie

**SOUND AFFAIR
RECORDING STUDIOS**
2727 No. G. Croddy Way
Santa Ana, CA 92704
Contact: Ron Leeper

DOPPLER STUDIOS, INC.
1922 Piedmont Circle, N.E.
Atlanta, GA 30324
Contact: Wilbur Caldwell



P.O. Box 1060 Coconut Grove, Florida 33133

db Bookcase

Please indicate the number of copies of each title you want and enclose check or money order for the total amount. In New York State, add applicable sales tax. Outside U.S.A. add \$1.00 per book. Allow several weeks for delivery. Address your order to:

Sagamore Publishing Co.
1120 Old Country Road
Plainview, New York 11803

	Quan.	Quan.	Quan.	Quan.	Quan.
1	10	19	28	37	
2	11	20	29	38	
3	12	21	30	39	
4	13	22	31	40	
5	14	23	32	41	
6	15	24	33	42	
7	16	25	34	43	
8	17	26	35	44	
9	18	27	36	45	

Total payment enclosed \$ _____ (Include N.Y.S. sales tax if applicable or \$1.00 per book foreign)

Name _____

Address _____

City, State, Zip _____

Check must be in U.S. funds drawn on a U.S. bank.

2. Sound Recording. (2nd ed.)

John M Eargle A graphic, non-mathematical treatment of recording devices, systems and techniques and their applications. Covers psychoacoustics, physical acoustics, console automation, signal processing, monitor loudspeakers, basic microphone types, audio control systems, stereophonic and quadrasonic sound, magnetic and disk recording, and devices used to modify basic recorded sounds. 320 pages **\$22.95**

3. Acoustic Design, M Rettinger

New, THIRD edition completely revised. Covers room acoustics and room design, with many practical examples. 1977. 287 pages **\$24.50**

38. Television Broadcasting: Equipment, Systems, and Operating Fundamentals.

Harold E Ennes An extensive text covering fundamentals of the entire television broadcasting system. Discusses NTSC color systems, camera chains, sync generators, recording systems, mobile and remote telecasts, tv antenna systems. Excellent for new technicians and operators as a source of valuable reference data for practicing technicians. Tables, glossary, exercises and answers. 656 pages **\$22.95**

39. Reference Data for Radio Engineers.

ITT Staff 5th Ed. The latest edition of one of the most popular reference books for radio and electronics engineers, as well as for libraries and schools. Complete, comprehensive reference material with tables, formulas, standards and circuit information. 45 chapters, 1196 pages with hundreds of charts, nomographs, diagrams, curves, tables and illustrations. Covers new data on micro-miniature electronics, switching networks, quantum electronics, etc. **\$34.95**

1. The Technique of the Sound Studio.

Alec Nisbett A handbook on radio and recording techniques whose described principles are equally applicable to film and television sound. 60 diagrams, glossary, index. 264 pages. Cloth. **\$33.95**

4. Noise Control, M Rettinger

Revised and enlarged into a separate volume. Covers noise and noise reduction, measurement and control. Several graphs and charts. 1977. App. 400 pages **\$28.50**

20. The Audio Cyclopedia (2nd ed.).

Dr Howard M Tremaine Here is the complete audio reference library in a single, updated volume. This revised edition provides the most comprehensive information on every aspect of the audio art. It covers the latest audio developments, including the most recent solid-state systems and integrated circuits. It spans all subjects in the field of acoustics, recording, and reproduction. With more than 3,400 related topics, each topic can be instantly located by a unique index and reference system. More than 1,600 illustrations and schematics help make complicated topics masterpieces of clarity. 1760 pages. Hardbound **\$44.95**

25. Operational Amplifiers-Design and Applications.

Burr-Brown Research Corp A comprehensive new work devoted entirely to every aspect of selection, use, and design of op amps - from basic theory to specific applications. Circuit design techniques include i.c. op amps. Applications cover linear and non-linear circuits, A/D conversion techniques, active filters, signal generation, modulation and demodulation. Complete test circuits and methods. 474 pages **\$46.50**

31. Solid-State Electronics.

Hibbard A basic course for engineers and technicians, and an extremely practical reference book for anyone who wants to acquire a good, general understanding of the semiconductor principles. Features questions and answers, problems to solve. 1968. 169 pages **\$32.50**

32. Circuit Design for Audio AM / FM, and TV.

Texas Instruments Texas Instruments Electronics Series. Emphasizing time- and cost-saving procedures, this book discusses advances in design and application as researched and developed by TI communications applications engineers. 1967. 352 pages **\$34.50**

37. Television Broadcasting: Systems Maintenance (2nd ed.).

Harold E Ennes A thorough treatment of modern television maintenance practice, covering maintenance of the tv broadcasting system from switcher inputs to antenna. Discusses test and operation of systems, test and measurements, including proof of performance for both visual and aural portions of the installation. 624 pages **\$22.95**

6. Sound System Engineering.

Don and Carolyn Davis The first of its kind, this book is the one source of sound information you can rely on to give you everything you must know to design, install, and service commercial sound systems. The book covers acoustics environments, design applications, equalizing, installations, and interfacing. Hundreds of drawings, photos, charts, and graphs are supplied. 1975. 296 pages. Hardbound **\$21.95**

28. Environmental Acoustics.

Leslie L Doelle Applied acoustics for people in environmental noise control who lack specialized acoustical training, with basic, comprehensible, practical information for solving straightforward problems. Explains fundamental concepts with a minimum of theory. Practical applications are stressed, acoustical properties of materials and construction are listed, actual installations with photos and drawings are included. Appendixes illustrate details of 53 wall types and 32 floor plans, and other useful data. 246 pages. **\$47.50**

36. The Handbook of Noise Control (2nd ed.).

Cyril M Harris Leading noise control authorities share their strategies and know-how in this in-depth treatment of all aspects of noise control. Tables facilitate rapid solutions to practical problems, and illustrations show noise control techniques for a range of common problems. Coverage includes the social, psychological, physiological, and legal aspects of noise and noise control. Hardbound **\$52.25**

40. Studio Acoustics.

M Rettinger The author provides those first design principles of sound recording studios that are required for satisfactory vocal and instrumental recording conditions. All equations are presented in both English and MKS systems of measurement. Metric equivalents follow in parentheses when the studio descriptions include linear dimensions. The book is divided into three sections: Basics, Studios and Electroacoustics. 241 pages **\$35.00**

New Products

POWER AMPLIFIER



• Heil Sound's Pro 400B is the latest edition to their series of high level power amplifiers. All Heil amplifiers use an exclusive MOD-U-PACK design that allows the entire left or right side of an amplifier to be unplugged and a spare module plugged in for instant service, should some problem arise during an important gig. The PRO 400B uses Heil PPC (Passive Protection Circuitry). Because the audio signal never sees this extra but important circuit, the most transparent sound is possible. Heil's exclusive Auto-Match circuit automatically selects either balanced or unbalanced inputs, eliminating the need to buy additional transformers. LED clip lights monitor each channel. RMS continuous sine wave output in the mono mode is 515 watts into 8 ohms. Used in a two-channel configuration, the PRO 400B produces 250 watts per channel into a 4-ohm load. The amp will produce well over 320 watts into a two-ohm load. THD is .09 percent or lower from 10 Hz to 30 kHz. The amplifier uses massive heat sinks and a huge power supply. The PRO 400B weighs 36 lbs. and measures 7-in. high by 19-in. wide by 13-in. deep.

Mfr: Heil. LTD.

Circle 48 on Reader Service Card

BELT-PACK HEADPHONE AMP

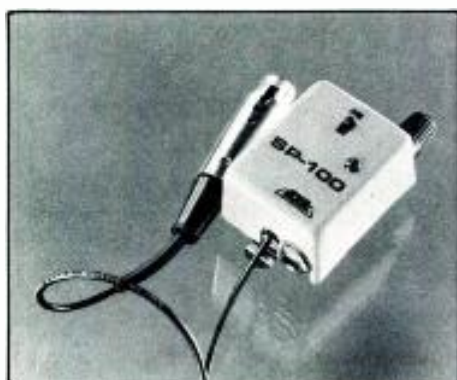

• AXE's SP-100 belt-pack headphone amplifier is suited for monitoring mic or line level signals as well as for general audio system troubleshooting. It can even be used as a signal tracer to trace the audio path through an amplifier. The unit's high input impedance allows minimum circuit loading, and makes it ideal for tuning wireless microphone receivers, setting up and balancing piano pick-ups, quality-testing microphones, and as a "listen only" intercommunication headset amp with variable gain. The SP-100 weighs 4 ounces and features long battery life, low noise, wide frequency response, and it can accommodate almost any audio signal source: high or low impedance, balanced or unbalanced, mic or line level.

Mfr: AXE

Price: \$74.95

Circle 49 on Reader Service Card

ONE-THIRD OCTAVE, PASSIVE EQUALIZER

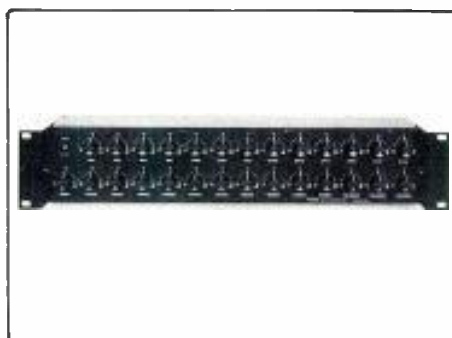

• White Instruments' Model 4520 One-Third Octave, Passive Equalizer is the latest addition to their stable of graphic equalizers, and the fifth in their series of passive equalizers. It features 27 single-tuned L-C filters on I.S.O. one-third octave frequency centers from 40 Hz through 16 kHz. These filters are individually tuned to a tolerance of ± 3 percent of center frequency and continuously adjustable to a maximum insertion of 10 dB. The equalizer uses mil-spec. conductive plastic, rotary potentiometers. It features two outputs and an accessory, octal socket into which optional, low-level crossover networks may be installed for bi-amp operation. An EQ in/out switch is located on the front panel to bypass the filters, but not the crossover network. The unit weighs 6 lbs. and requires 3½ inches of rack space. Finish is brushed, black aluminum with white nomenclature. Matching security cover is included.

Mfr: White Instruments, Inc.

Price: \$725.00

Circle 56 on Reader Service Card

LINEAR-PHASE ELECTRONIC CROSSOVER



• FM Acoustics Ltd's FM 236 Linear-Phase Electronic Crossover employs six proprietary six-pole filters which achieve a 36 dB/octave slope. Computer-selected capacitors, military-grade metal film resistors, and individually tuned transistor stages guarantee accuracy. All buffers and amplification modules use the hand-tuned FM Acoustics thermo-coupled Class A technology and are built out of selected discrete components instead of integrated circuits. Output stages feature low dynamic output impedance and are able to drive almost any length of cable and any impedance with stability. This low output impedance is achieved by careful circuit design instead of by high feedback techniques currently used in op-amp designs. All 94 transistors in the FM 236 are individually selected by electronic testing equipment. The design of the FM 236 achieves results such as perfect step response, no overshooting, accurate square-wave response, wide frequency response, no ringing, and the phase-linear response characteristic. The unit is 19-inch rack-mountable and has a height of 44 mm. The frequency-determining crossover modules sit behind an acrylic cover plate on the front panel and can be easily exchanged. The amplifier and speakers are protected by an automatic output muting circuit. There are 22 separate high and low-pass crossover modules available for both channels. Custom crossover frequency modules can be manufactured to order.

Mfr: FM Acoustics

Circle 51 on Reader Service Card

MULTI-TRANSPORT CONTROLLER/EDITING SYSTEM

• BTX Corporation's new multi-transport controller/editing system directly controls and synchronizes any combination of up to four multi-track audio or video transports while supporting additional transports in chase-lock synchronization mode. Known as SOFTOUCH™, the system consists of three distributed intelligent modules: the Softouch Controller/Editor, Shadow II Synchronizer, and the Cypher Time Code System, all networked via RS-232. Softouch offers cost-effective solutions to time-code applications, transport control and synchronization, audio dialogue replacement, audio sweetening, and sound effects assembly and editing. Based on new microprocessor technology, the new system offers unique standard features such as SOFTKEYS™, which permits execution of repetitive pre- and post-production editing routines at the touch of a key. The user can define, edit, and store as many as 16 Softkeys at a time. Softouch displays are information centers which allow easy human interaction with the system. They feature two full eight-digit time code displays as well as a real-time status matrix. These displays provide transport control and location, servo mode, and record status information simultaneously for four transports. Additionally, an alphanumeric command display prompts the user throughout the editing process. Time code applications are simplified and easily controlled with Softouch. Generating or



reading SMPTE, EBU, VITC, or 24-frame code, regenerating code, or jam-syncing code is accomplished by pressing a command key. The ability to trigger events via time code is also facilitated, as is the conversion of feet (or meters) and frames to time code for film applications. Another unique feature is a memory to contain all pre- and post-roll plus beep tone trim, mark in/out, and record in/out data for up to 100 loops. Softouch allows separate assigns for each transport plus master record enable, full wild machine control, the ability to auto-locate any transport independently of other activity, as well as to control the record

window during looping functions. Battery back-up for off-line Softkey entry, protection, and transportation considerations is also provided. An RS-232 computer interface accepts over 50 multi-track audio and/or video transports. The controller/editor console, synchronizer(s), time code system, interfaces, and all necessary cabling are included in packaged-system format. Additionally, the system's building-block approach allows existing and future BTX Shadow or Cypher customers to upgrade to a fully configured Softouch system.

Mfr: BTX Corporation

Circle 52 on Reader Service Card

PHASE CHECKER

• Sounder Electronics' Model 500 Phase Checker determines and displays the polarity of all audio equipment and quickly eliminates the problems of phase distortion, bass cancellation, and loss of acoustic power caused by polarity errors. The Phase Checker consists of two units: the Pulse Generator to excite the system, and the Polarity Detector to show the results. An internal electret condenser microphone in the Detector and Cannon phone and phono jacks on both units make it easy to test all audio equipment. The Phase Checker uses standard 9-volt batteries and is guaranteed for one year.

Mfr: Sounder Electronics

Circle 53 on Reader Service Card



FIVE NEW MONITORS

• Auratone Corporation has developed a new series of multi-driver Quality Sound Monitors. The five new models include the T5 Ultra-Compact Two-Way, T6 Sub-Compact Two-Way, T66 Compact Two-Way, QC66 Quality Control Three-Way, and RC66 Road Cube Two-Way monitors. Extensive design and development efforts have resulted in clean broad-range response, precise stereo imaging, durability, and power handling commensurate with professional applications. The systems features polypropylene low-frequency drivers, wide dispersion dome mid-ranges, tweeters, and super tweeters. All models have six or ten element crossover networks with precision metalized film polyester capacitors and aircore inductors mounted on fiberglass/resin printed circuit boards. With the exception of the RC66 Road Cub Two-Way, all Auratone Quality Sound Monitors are produced in mirror-image pairs for enhanced stereo imaging. The enclosures are manufactured from low-resonance Super-Acoustic-wood™, a high-density wood-based product with acoustic properties superior to the particle board used by many speaker manufacturers.

Mfr: Auratone Corp.

Circle 54 on Reader Service Card

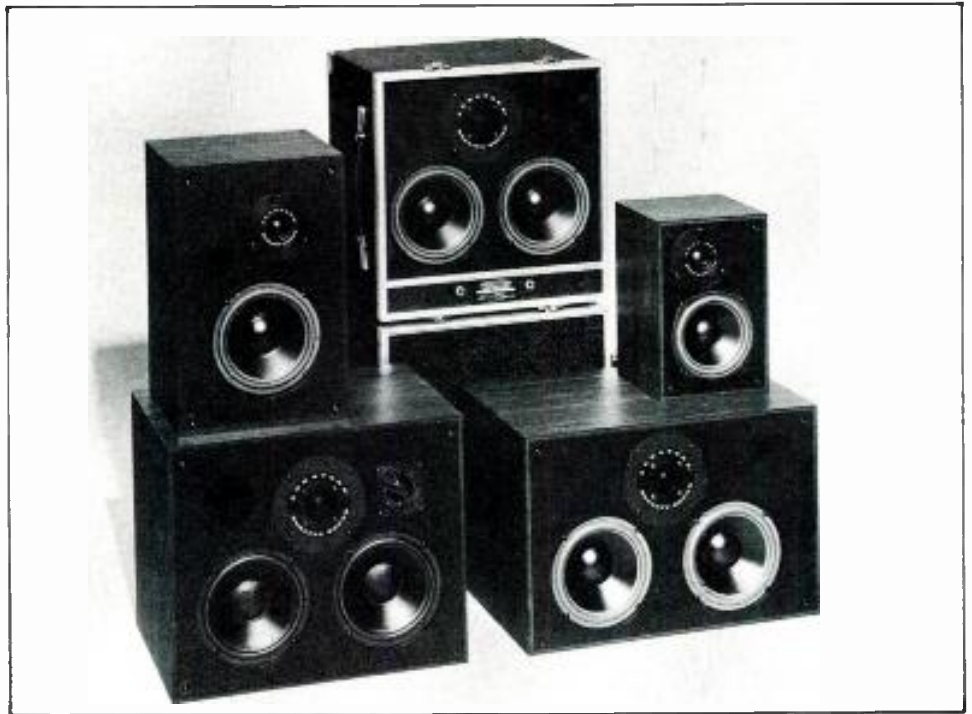

COMPACT HIGH QUALITY MONITOR

• Calibration Standard Instruments' MDM-TA2 Time Align® Nearfield Monitor™ incorporates several unique features. A Position/Program switch on the front panel adjusts the response for listening position (NFM or Distant) and program material (Original or Final) so that proper equalization may be applied to the original recording or broadcast to overcome upper-range losses in the recording or broadcast chain. The MDM-TA2 is claimed to be the first monitor to provide a Polarity switch on the front panel, thus allowing absolute polarity of program material to be checked easily. The response of the MDM-TA2 is ± 3 dB from 60 Hz to 20 kHz, and it can produce 108 dB SPL at 1 meter. The MDM-TA2 is sold in pairs that are matched within ± 0.5 dB. Like all C.S.I. monitors, the MDM-TA2 features Protekt™, which allows amplifiers of up to 300 watts/channel to be used safely.

Mfr: Calibration Standard Instruments
Circle 55 on Reader Service Card



Classified

Closing date is the fifteenth of the second month preceding the date of issue.
 Send copies to: Classified Ad Dept.
 db THE SOUND ENGINEERING MAGAZINE
 1120 Old Country Road, Plainview, New York 11803

Minimum order accepted: \$25.00
 Rates: \$1.00 a word
 Boxed Ads: \$40.00 per column inch
 db Box Number: \$8.50 for wording "Dept. XX," etc.
 Plus \$1.50 to cover postage

Frequency Discounts: 6 times, 15%; 12 times, 30%

ALL CLASSIFIED ADS MUST BE PREPAID.

USED RECORDING equipment for sale.
 Dan (415) 441-8934.

CASSETTE DUPLICATION IN real time from 10-10,000. Nakamichi cassette decks used for optimum quality. Best rates, labels, inserts and shrink wrap available. Fast turn around. Audiohouse (303) 751-2268.

NAGRA E for sale (NON-SYNC) portable recorder with carrying case, manual and AKG D-160. MINT CONDITION, barely used. \$1995.00. Call Rick (305) 532-7112 Eves.

MCI JH-500 Console, Allison automation, JH-16 multitrack recorder with 24 track heads. Very reasonable price. Contact: Gregory King (305) 425-1001 (Florida).

"KNOW HOW YOUR SPEAKERS WILL SOUND BEFORE YOU BUILD!" New program gives you response and more on any Commodore home computer—\$19.95 —Audio Soft, 90 Robie Ave., Buffalo, NY 14214.

THE LIBRARY... Sound effects recorded in STEREO using Dolby throughout. Over 350 effects on ten discs. \$100.00. Write The Library, P.O. Box 18145, Denver, CO 80218.

NEUMANN U-87, U-47, four each. Used once. In warranty. \$849, \$829. Call John (512) 690-8187.

FOR SALE

- Interface Electronics 24 x 8 x 2 (108K Model). Main Console w/Anvil Case—\$4,000.00.
 - Interface Electronics 16 x 8 Monitor Console, 24 Input Main Frame w/Anvil Case—\$3,500.
 - 26 Channel Mic Snake, Monitor Snake and Balanced Splitter Box—\$1,200.00
- SATURN SOUND & STUDIOS**
 (305) 832-2148

FOR SALE

MICROPHONES. Immediate delivery via UPS. All popular models in stock. Best prices you'll see in '83; PLUS we pay freight. UAR Professional Systems. 8535 Fairhaven, San Antonio, TX 78229. (512) 690-8888.

FREE 32pg Catalog & 50 Audio/Video Applic.
 PWR SUPP EQ
 PHONO, MIC
 TRANS, ACN,
 TAPE, VIDEO,
 LINE, OBC

Stereo/Mono Per Ampl.
 Video & Audio Dist Amplis. TV Audio & Recd Prod Consoles

8-in/2-out, 12-in/4-out, 18-in/4-out

OPAMP LABS INC (213) 934-3566
 1033 N Sycamore Av LOS ANGELES CA, 90038

16-TRACK FOR SALE

MCI "JH100-16" 16-track tape recorder. 1/2 life heads, certificate available, good working condition. \$10,000. For further information or to make an appointment, call Pat Camino, Elan Communications, (305) 593-9947.

DIRECT FROM BROADWAY

USED SOUND EQUIPMENT SALE

PETER PAN • FIDDLER • CAMELOT
 KING & I • CHORUSLINE • DOLLY
 Wireless Microphones
 Used By The Stars
 AMPS • MIXERS • RECORDERS
all guaranteed

SOUND ASSOCIATES, INC.
 424 WEST 45 ST. • N.Y., N.Y. 10036
 TELEPHONE 212-757-5679

TECHNICS TURNTABLES IN STOCK! AKG, Neumann, UREI, Orban Eventide, dbx, Lexicon. Best pro-audio equipment. Lowest prices. IMMEDIATE DELIVERY. UAR Professional Systems. (512) 690-8888.

FOR SALE—AKG C-24 and other tube type condenser mics. (415) 441-8934 or 527-6167.

PRO AUDIO IN STOCK—ready to ship. Top lines, top dollar trade-ins, clearance specials. Call or write for our prices. Professional Audio Video Corporation, 384 Grand Street, Paterson, NJ 07575 (201) 523-3333.

dbx 904 GATES three in custom powered rack with mic preamps, cannon umbilical to mixer. Mint, no bugs ever. Steal all for \$750. Merimack (716) 442-5020 PeeWee.

AGFA CHROME and normal bias BLANK CASSETTES. CUSTOM LOADING to the length you need. Your music deserves the best—your budget deserves a bargain. GRD P.O. Box 13054, Phoenix, AZ 85002. (602) 252-0077.

FOR SALE: Scully "The Lathe" Disc Cutting System w/Ortofon "Blue" Head, Custom Amps, Ikegami Camera & Monitor, Nikon Stylus Inspection Scope. All for \$39,500 US\$. Call Richard Lee at Criteria (305) 947-5611.

SENSURROUND LOW FREQUENCY ENCLOSURES with 18" CER-VEG 300 watt die-cast 96 oz. magnet driver. \$195.00. Empirical Sound, 1234 East 26th Street, Cleveland, OH 44114. (216) 241-0668.

FREE COMPUTER MUSIC CATALOG. Introduction to principles of computer music and digital audio. Complete guide to DMS' products. Write Digital Music Systems, P.O. Box 1632, Boston, MA 02105. (617) 542-3042.

BLANK AUDIO AND VIDEO CASSETTES direct from manufacturer. below wholesale. any length cassettes. 4 different qualities to choose from. Ampex and Agfa mastertape—from 1/2-inch to 2-inch. Cassette duplication also available. Brochure Andol Audio Products, Inc., Dept. db, 42-12 14th Ave., Brooklyn, NY 11219. Toll free 1-800-221-6578, ext. 1, NY residents (212) 435-7322.

WANTED

WANTED: TRANSCRIPTION discs, any size, speed. Radio shows, music. P.O. Box 724-db, Redmond, WA 98052.

Employment Wanted: Management/Supervisory position with reputable Pro Audio manufacturing firm. Will relocate, travel. Self motivated, hard working. Send responses to: **Dept. 21, db Magazine, 1120 Old Country Rd., Plainview, NY 11803.**

SERVICES

MAGNETIC HEAD relapping—24 hour service. Replacement heads for professional recorders. IEM, 350 N. Eric Drive, Palatine, IL 60067. (312) 358-4622.

ACOUSTIC CONSULTATION—Specializing in studios, control rooms, discos. Qualified personnel, reasonable rates. Acoustilog, Bruel & Kjaer, HP, Tektronix. Ivie equipment calibrated on premises. Reverberation timer and RTA rentals. Acoustilog, 19 Mercer Street, New York, NY 10013. (212) 925-1365.

EMPLOYMENT

AUDIO TECHNOLOGY INSTRUCTORS

Immediate opportunities for audio instructors with heavy multi-track industry experience. Selected candidate will have skills in recording, operational techniques and video sweetening. Full and part time positions available. If interested, send resume to:
 Mr. Harry Hirsch, Director of Education
CENTER FOR THE MEDIA ARTS
 226 West 26th Street New York NY 10001
 Equal Opportunity Employer m/f

AUDIO/VIDEO FREELANCE WRITER NEEDED

Do you have a basic working knowledge of audio and video recording systems? Can you write a competent paragraph? Would you like to escape the hassles of New York or L.A. for a more laid-back lifestyle? Nashville needs you! I've got more work than I can handle, both editorial and advertising. Please send your resume to: **db Magazine, Dept. 51, 1120 Old Country Rd., Plainview, NY 11803.**

Senior audio maintenance technician wanted for top studio. 5 years experience minimum. Excellent pay. Please send resume to: **db Magazine, Dept. 70, 1120 Old Country Road, Plainview, NY 11803.**

RECORDING ENGINEER/TECHNICIAN

Religious audio and video production facility seeks Recording Engineer/Technician with strong audio production skills and electronics background. Position includes recording/mixing/editing audio for various electronic media resources, plus some maintenance work. Desirable for applicant to have recording experience with orchestras, small ensembles and voice talent. Video experience helpful. Send resume to: **Personnel Office, RLDS Auditorium, P.O. Box 1059, Independence, MO., 64051, ATTN: David Wheaton.**

Audio Circuit Design Engineer

Due to recent expansion and increased business activities UREI has an opening for a product designer. Applicant must have substantial experience in all phases of audio circuit design, B.S. preferred. UREI offers competitive salaries and excellent benefits.



8460 San Fernando Road
 Sun Valley, California 91352

Forward resumes to
 R.B.Combs

WANTED

Full Time **INSTRUCTORS** Part Time
FOR AUDIO RECORDING TECHNOLOGY

To teach basic and advanced theory and operation of multi-track recording studio equipment.

Audio field experience required. Teaching experience preferred.

Location—historic Greenwich Village.
 Salary—attractive; commensurate with background, experience and responsibility of position.

Send detailed resume, including salary history to:



Philip Stein, Director
Institute of Audio Research
 64 University Place
 Greenwich Village
 New York, N.Y. 10003



Have you misplaced your db again? Our high quality, royal blue vinyl binders keep 12 copies of db neat and handy for ready reference.

Just \$9.95, available in North America only. (Payable in U.S. currency drawn on U.S. banks.) **ORDER YOURS NOW!!**

Sagamore Publishing Co., Inc.
 1120 Old Country Road
 Plainview, NY 11803

YES! Please send db binders @ \$9.95 each, plus applicable sales tax. Total amount enclosed \$

Name

Company

Address

City

State Zip

People, Places

• **Studer** professional audio equipment may now be purchased through a limited network of independent professional audio dealerships, according to an announcement by **Thomas E. Mintner**, director, Studer Products. Previously, all products in the Studer line were made available exclusively through direct distribution by the Swiss company's U.S. subsidiary, **Studer Revox America, Inc.** "In the past few years Studer recorders have captured an ever-increasing share of the market," says Mintner. "In order to meet this demand, and at the same time preserve our high standards for customer service, Studer has initiated a program of distribution through a few carefully selected dealerships." Dealers currently authorized to carry the Studer line are: **Audio Engineering Associates** of Pasadena, California; **Bridgewater Custom Sound** of Harvey, Illinois; **Doug Brown Enterprises** of Tulsa, Oklahoma; **Cramer Video** of Needham, Massachusetts; **Midcom, Inc.** of Arlington, Texas; **Emco, Inc.** of Rockville, Maryland; **Pro Audio General Store** of Atlanta, Georgia, Coral Springs, Florida, and Carol Stream, Illinois, and **Studio Sonics Corporation** of Schaumburg, Illinois. Studer products available through the dealer network include the A810 Professional/Broadcast Recorder, A710 Professional Cassette Deck, A80VU recorder (4 and 8 track only), Telephone Hybrid, Telephone Audio System, Balancing Unit, A726 FM Tuner, and 2706 Monitor Loudspeaker. Studer mixing consoles, A800 multi-track recorders, and A80VU recorders (2 and 16/24 track) will continue to be available only through direct distribution by Studer Revox America. Studer offices are located in Nashville, New York, Los Angeles, Dallas, Chicago, and San Francisco. Distribution of Revox professional products (PR99,

B77, and B710) will continue to be handled separately through the company's Revox Division. In most cases, however, Studer dealers will also be authorized to sell Revox professional products.

• **Cetec Gauss**, manufacturer of high speed tape (cassette) duplicating systems, has announced the sale of its cassette duplicators and equipment to **China Records**, a leading manufacturer of records and music cassettes in The People's Republic of China. China Records, which distributes music products throughout Asia, has installed the Cetec Gauss 2400 duplicating system in its new facility in Guangzhou (Canton), announced **Mort Fujii**, president of Cetec Gauss. The 2400 duplicating system gives China Records the capability to duplicate music on metal particle and chromium oxide cassettes and microcassettes, as well as on standard ferric oxide tapes. "The penetration of high speed tape duplicating equipment in The People's Republic of China is significant," Fujii said, "because it indicates that China is prepared to step forward and advance its technology in the music and tape industry."

• As a result of the consolidation of all Altec manufacturing activities in Oklahoma City and the recently completed sale of their Manchester Avenue facility in Anaheim, Altec corporate offices will be operating from a new address. Altec corporate headquarters—including administration, engineering, sales, marketing and marketing communications—are now located

at: 1250 Red Gum Street, Anaheim, CA, 92806; the new mailing address is: Altec Lansing, P.O. Box 3113, Anaheim, CA 92803. Commenting on the corporate relocation and Oklahoma City move, Altec president **William Fowler** stated that, "Altec headquarters will remain in Southern California because of the importance of our contacts in this area with acoustical consultants, major domestic and international sound contractors, the film industry and the **Disney** organization. At the same time, consolidating all manufacturing at our Oklahoma City facility allows us to take full advantage of that plant's modern, highly efficient capabilities and central location."

• **Sony Professional Audio Products** has appointed six new MCI/Sony dealers, **George Currie**, vice president and general manager, announced. The expansion of the national dealer network is designed to provide better service to the professional recording industry. Mr. Currie said.

The recent dealer appointments are: **Lake Systems**, Newton, Massachusetts; **Leo's Professional Audio, Inc.**, Oakland, California; **Pro Audio General Store, Inc.**, Coral Springs, Florida; **Professional Products**, Bethesda, Maryland; **Studio Supply**, Nashville, and **Westlake Audio, Inc.**, Los Angeles. All MCI/Sony dealers sell the complete line of MCI/Sony tape recorders, mixing consoles, automation systems and accessories. The following firms also are MCI/Sony dealers: **Audio Industries**, Hollywood, California; **Audio-techniques**, Stamford, Connecticut; **Milam Audio**, Pekin, Illinois; **Pro Audio Systems**, Seattle; **Southwest Pro Audio**, Austin, Texas; **Studio-works**, Charlotte, North Carolina.

• **Mitsubishi Electric America** has acquired **Digital Entertainment Corporation (DEC)** in return for providing a substantial financial package to DEC. Digital Entertainment Corporation will assume all marketing and sales responsibilities of the Mitsubishi Electric pro audio products, which primarily consist of a range of digital audio recorders for studio and broadcast use. **Tore Nordahl**, founder of Digital Entertainment Corporation, will remain president and chief executive officer while Mitsubishi Electric America chairman **Yoshito Yamaguchi** will assume the chairmanship of DEC. Headquarters of DEC will remain in Danbury, Connecticut. A major sales and support office is scheduled to open in Manhattan shortly. DEC's Hollywood office is already open for business at 733 N. Fairfax Avenue. **Sonny Kawakami** of Mitsubishi Electric Sales America is assuming the position of vice president Marketing for DEC, while **Lou Dollenger** (Mitsubishi Electric in Chicago) is moving to the New York area to become Marketing manager. Industry veteran **Bill Van Doren** is Regional manager at the Hollywood office.

• If **Reeves Teletape's** clients are an indication, there seems to be a continuing and increasing demand for off-line editing facilities. "As a result, says RT president **Caddy Swanson**, "we have added off-line to our other editorial services in order to provide the optimum creative and budgetary flexibility for our clients." One reason for the off-line demand is that many producers are shooting on one inch and then producing $\frac{3}{4}$ " dailies with SMPTE code so that they can edit off-line. Decisions are then made and approvals granted with the full intention of conforming to one inch for airing and distribution. To meet this need, RT's off-line editing room provides a lower hourly rate and an editing system that produces the necessary documentation. (A computer tape or typewritten hard copy is ideal if the client's project provides the necessary time frame to go off-line.)

Another emerging market for off-line are productions that originate on $\frac{3}{4}$ " and are destined to be distributed or aired on $\frac{3}{4}$ ". These projects normally require opticals available in the one inch medium (titles, wipes, digital effects). RT's multi-format editing rooms have been designed for on-line $\frac{3}{4}$ " editing, and the rate that the client pays for this service has been set midway between that for off-line and on-line editing suites.

• **Donald A. Puluse**, one of the nation's most respected recording engineers, credited with twelve gold and platinum records, has been named chairman of the Music Production and Engineering Department at Boston's **Berklee College of Music**, as announced by Berklee President **Lee Eliot Berk**. Puluse, who assumes his Berklee position September 1, is a leading figure in the recording industry, having guided the production of such hits as **Bob Dylan's** *New Morning*, **Sly Stone's** *Dance to the Music*, **Janis Joplin's** *Joplin In Concert* and **Chicago's** *Chicago III*. At Berklee, Puluse will guide the educational planning and development of the innovative Music Production and Engineering major, the first such program in a U.S. college of music.

• **John Matarazzo** has recently joined the Magnetic Tape Division of **Agfa-Gevaert, Inc.**, Teterboro, New Jersey, in the position of assistant technical manager. He will be responsible for providing technical support for the sales staff, coordinating customer and distributor open houses, and for conducting in-house personnel training. Mr. Matarazzo had been employed by **RKO Tape Corporation** as director of Quality Assurance for the past 10 years.

• **Bob Yesbek**, owner of **Omega Recording Studios**, has announced the acquisition of a second 24-track music studio located in downtown Washington, D.C. Formerly "Room 10," the new facility is still serving its regular clientele while also handling the overflow business from Omega's popular suburban studios. The new studio features MCI console and tape machines and Urei monitors. The original Kensington, Maryland, studio continues to offer complete music and media production services using Studer tape machines and API and Audionics consoles. Omega plans to centralize both operations into one large 3-studio complex in the near future.

• **Bose Corporation** has announced the appointment of **Austin K. Pryor** as director of Marketing and Strategic Planning. Mr. Pryor will supervise the company's professional products management groups and other groups. Mr. Pryor reports to **John J. Geheran**, vice president of Marketing and Sales.

• **3M** announced that it has sold the service support capabilities and spare parts inventory for its professional analog audio recorders to **Electro-Technology Corporation**, Menlo Park, California. The sale includes a licensing agreement to manufacture spare parts to repair or rebuild the recorders which were last manufactured in 1979 by the former Mincom Products Division of 3M. According to **Art Cuscaden**, technical service supervisor, Broadcast and Related Products Division, the agreement includes all existing spare parts, engineering data, vendor information and test and manufacturing fixtures needed to provide repair services or parts to current owners of the equipment. In addition, the agreement provides for the training of Electro-Technology personnel in the use of the fixtures and equipment.

• Effective immediately, **Schubert Systems Group** has expanded to a full service sound reinforcement company by acquiring the assets of **Innovative Audio Inc.**; in addition, **David Morgan** has been taken on as a new partner. Founded in 1979 by **S. Roy Schubert** and **Dirk Schubert**, the company in the past has provided electronics, monitors and PA systems for **Toto**, **Willie Nelson** and **The Doobie Brothers**. This season, the new company is already on the road with **Willie Nelson**, **Paul Anka**, **The Hollies** and **Christopher Cross**. SSG develops or customizes many of its own products, including mixing consoles, crossovers, equalizers, intercoms and snake systems. In addition, SSG plans to introduce its own line of programmable mixing consoles in 1984/85. The current complement of equipment owned and operated by SSG includes eight **Jim Gamble Associates** consoles with proprietary SSG modifications, all **JBL** bi-amped monitor systems, and full flying 4-way **JBL** phased array PA systems, all driven by SSG transformerless minimum delay crossovers and **Cerwin-Vega** Metron amplifiers. In addition, the company provides a full range of analog and digital effects, including two new **Lexicon 224X** digital reverb with **Larc** remote controls.



Take Us For Granted

With 24 tracks going, you don't have time to reach over and adjust for tape-induced level variation. You want to be able to forget about the tape.

Which is why we test every reel of our 2" Grand Master® 456 Studio Mastering Tape end-to-end and edge-to-edge. To make certain you get a rock-solid readout with virtually no tape-induced level variation from one reel of 456 to

another or within a single reel.

No other brand of tape undergoes such rigorous testing. As a result, no other brand offers the consistency of Ampex Tape. The consistency that lets you forget our tape and concentrate on the job.

AMPEX

Ampex Corporation • One of The Signal Companies 

Ampex Corporation, Magnetic Tape Division
401 Broadway, Redwood City, CA 94063
415/367-3809

Circle 11 on Reader Service Card

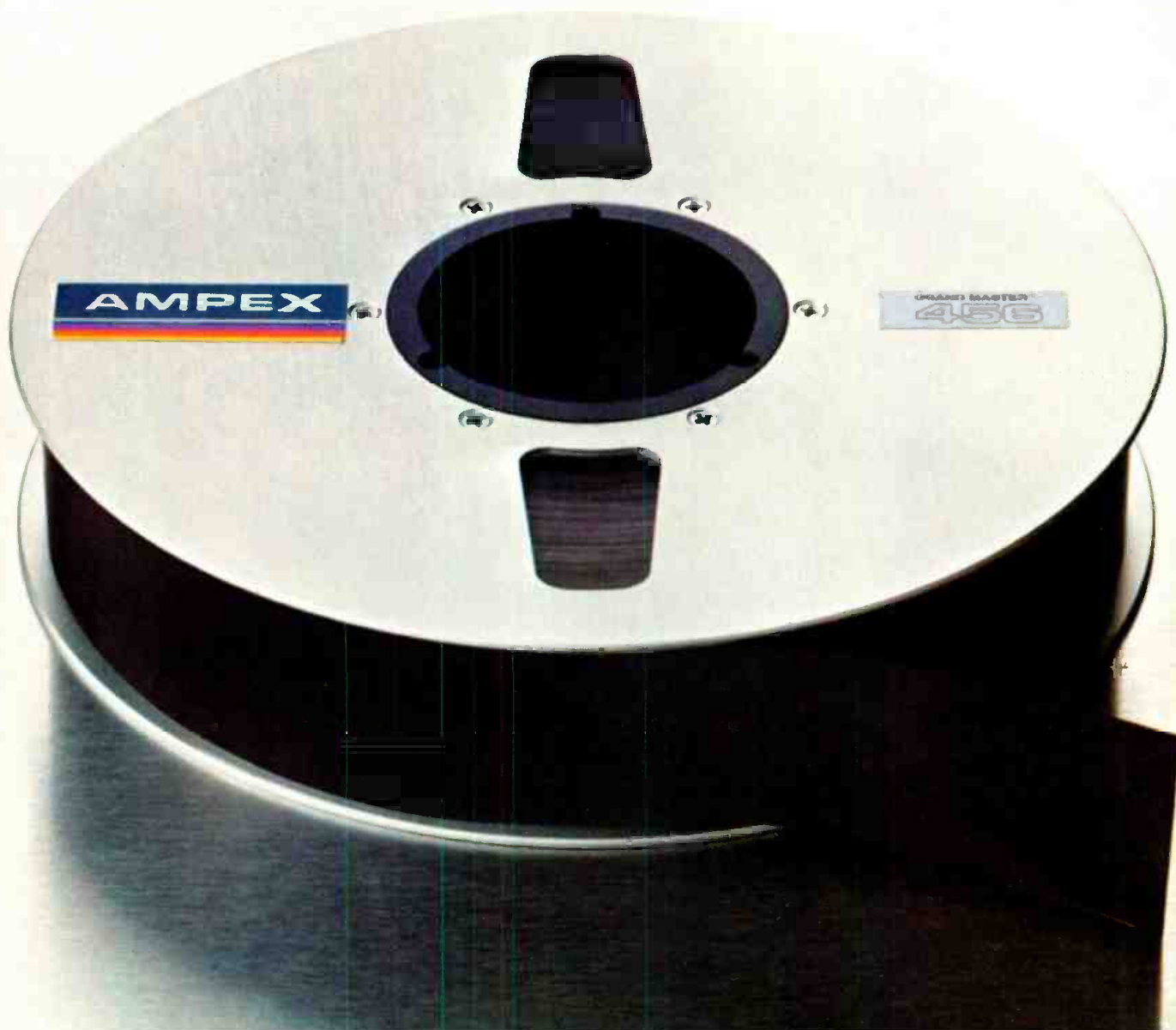

The Ampex ATR-800 is built to last.

Others talk about audio "workhorses". But only Ampex has been manufacturing reliable professional audio recorders since 1947. Recorders that can take everything you can dish out day after day.

The Ampex ATR-800 continues our tradition by offering you unmatched editing ease, complete interfacing capabilities with a variety of peripherals (synchronizers, editors, etc.), a rugged cast transport that maintains tape path alignment, standard built-in features without an accompanying

premium price tag, and a full range of accessories for all kinds of applications. And, as with all Ampex audio recorders, you get our worldwide sales and service support to keep your workhorse racing along.

Try the ATR-800. Another winning audio workhorse from Ampex.

For details, contact your nearest Ampex dealer, or write Willie

Scullion, National Sales Mgr., Ampex Corporation, Audio-Video Systems Division, 401 Broadway, Redwood City, CA 94063.

OUR WORKHORSES DON'T DIE YOUNG.

AMPEX

Ampex Corporation • One of The Signal Companies



Circle 12 on Reader Service Card